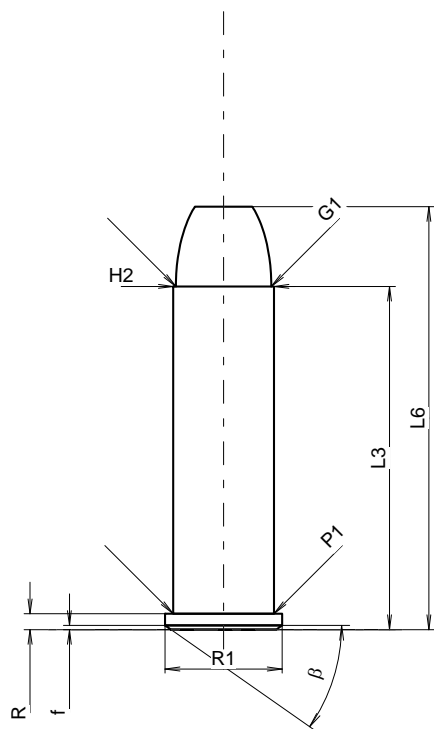

C.I.P.**357 Magnum**

TAB.	IV
Date	84-06-14
Révision	06-06-14

Pays d'origine: US

**CARTOUCHE MAXI****Longueurs**

L1	=	
L2	=	
L3 ¹⁾	=	32.77
L4	=	
L5	=	
L6	=	40.39

Culot

R ¹⁾	=	1.52	-0.25
R1	=	11.18	
R3	=		
E	=		
E1	=		
e min	=		
δ	=		
f	=	0.40	
β	=	35°	

Chambre à poudre

P1	=	9.63
P2	=	

Cône de raccordement

α	=	
S	=	
r1 min	=	
r2	=	

Collet

H1	=	
H2 ¹⁾	=	9.63

Projectile

G1 ¹⁾	=	9.12
G2	=	
F	=	
L3+G ¹⁾	=	43.27

Pressions (Énergies)**Méthode transducteur**

Pmax	=	3000 bar
PK	=	3450 bar
PE	=	3900 bar
M	=	17.50

Autres indications

Fe ¹⁾	=	0.25
delta L	=	

CHAMBRE MINI**Longueurs**

L1	=	
L2	=	
L3 ¹⁾	=	33.07

Cuvette

R ¹⁾	=	1.52
R1	=	11.28
R2	=	
R3	=	
r	=	

Chambre à poudre

E	=	
P1 ¹⁾	=	9.68
P2	=	

Cône de raccordement

α	=	
S	=	
r1 max	=	
r2	=	

Collet

H1	=	
H2 ¹⁾	=	9.65

Prise de rayures

G1 ¹⁾ *	=	9.09
G ¹⁾	=	10.50
α1 *	=	13°
h	=	2.46
s	=	8.69
i ¹⁾ *	=	4°45'
w	=	

Canon

F ¹⁾ *	=	8.79
Z ¹⁾	=	9.02

Rayures

b	=	2.69
N	=	6
u	=	476.00
Q	=	62.57 mm ²

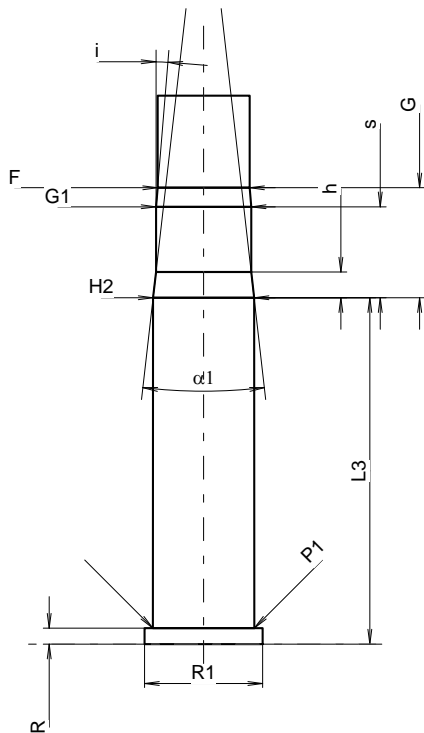

Échelle 1.39:1

Dimensions en << mm >>
Dimensions et tolérances pour les canons
d'épreuve: Voyez Annexe CR 1.

Notes: 1) A' contrôler pour la sécurité
* Dimensions de base