

# **SIGSAUER®**



## **SIG P226® X-Series Pistols®**

**OPERATOR'S MANUAL: HANDLING & SAFETY INSTRUCTIONS**



READ THE INSTRUCTIONS AND WARNINGS IN THIS MANUAL CAREFULLY BEFORE USING THIS FIREARM. DO NOT DISCARD THIS MANUAL.

THIS MANUAL SHOULD ALWAYS ACCOMPANY THIS FIREARM AND BE TRANSFERRED WITH IT UPON CHANGE IN OWNERSHIP, OR WHEN THE FIREARM IS PRESENTED TO ANOTHER PERSON.



# WARNINGS

## 1.0 SAFETY WARNINGS

**READ THIS ENTIRE MANUAL THOROUGHLY AND CAREFULLY PRIOR TO USING THIS FIREARM.**

The warnings in this operators manual are extremely important. By understanding the dangers inherent in the use of any firearm, and by taking the precautions described in this manual, you can experience a high level of safety in the use of your firearm. Failure to heed any of these warnings may result in serious injury or death to you or others, as well as severe damage to the firearm or other property.

**WARNINGS** in this manual identify a clear danger to the person performing that procedure. Warnings are identified by a red banner with the word **WARNING** in white, bold, uppercase letters and a **WARNING** icon. Failure to comply with a **WARNING** can result in serious injury or death to you or a bystander.



**WARNING**

**CAUTIONS** in this manual identify a risk of damage to the firearm being maintained. **CAUTIONS** are identified by a black banner with the word **CAUTION** in white, bold, uppercase letters.

**CAUTION**



# WARNINGS

**SIG SAUER**

As a valued SIG SAUER customer, we encourage you to visit [sigsauer.com](http://sigsauer.com). There you will find links to product information and updates, merchandise promotions, and educational videos that will be of interest to you as an owner of SIG SAUER products.

SIG SAUER firearms are designed to function reliably with proper care and knowledgeable use. You must understand the safe operation and use of your SIG SAUER firearm. Read and follow these instructions carefully. Do not use the firearm unless you fully understand these instructions and the safe operation of your firearm. Failure to heed any of these instructions may result in serious injury or death to you or others, as well as severe damage to the firearm or other property.

Your firearm comes equipped with effective, well-designed safety features. However, never rely completely on any safety mechanism. Safety mechanisms are designed to augment, not replace safe handling practices. Careless and improper handling of any firearm can result in an unintentional discharge.

Only your safe firearm handling habits will ensure the safe use of your firearm. Like all mechanical devices, the safety mechanisms are subject to breakage or malfunction and can be negatively affected by wear, abuse, dirt, corrosion, incorrect assembly, improper adjustment or repair, or lack of maintenance. Moreover, there is no such thing as a safety mechanism that is “childproof” or that can completely prevent accidental discharge from improper usage, carelessness, “horseplay”, or abusive handling.

The best safety is proper and applied training in safe firearm handling. Always handle your firearm as though you expect the safeties not to work.



# WARNINGS

## 1.0 SAFETY WARNINGS - CONTINUED

Do not load a cartridge into the chamber until you are ready to use the firearm. If your firearm is equipped with a manual safety, keep the safety ON until you are actually ready to use the firearm. Always move the safety fully to its engaged position and visually check it. The safety is not ON unless it is completely ON.

### ABUSIVE HANDLING

SIG SAUER firearms incorporate effective mechanical safeties. However, like any mechanical device, exposure to abusive conditions may have a negative effect on these safety mechanisms and cause them to fail to work as designed. Do not subject your SIG SAUER firearm to any type of abusive handling. This includes the firearm being dropped, impact to the firearm, or the firearm being struck by another object. Make sure you always maintain control of your firearm at all times. If your firearm does suffer an abusive event such as previously described, do not attempt to use the firearm. Keep the firearm pointed in a safe direction, unload and clear the firearm of all ammunition immediately, and have it inspected by a certified SIG SAUER armorer or gunsmith prior to using the firearm.

A safe direction is defined as an area in which, if the firearm were to discharge, no property damage would occur and no personal injury would result.

As previously noted, if your SIG SAUER firearm does suffer an abusive event, unload it immediately and have it inspected by a certified SIG SAUER Armorer or gunsmith prior to using the firearm.

Intentional or repetitive abusive handling of any SIG SAUER firearm will void the manufacturer's warranty and could render the firearm unsafe.



# WARNINGS

**SIG SAUER**

## **REPLACEMENT PARTS**

Do not attempt to disassemble your SIG SAUER firearm beyond the point explained in this manual. Disassembly beyond the instructions in this manual is restricted to a certified SIG SAUER armorer or professional gunsmith. Failure to comply with these restrictions will void your warranty.

Warnings and instructions about the use of some SIG SAUER replacement parts, assemblies, and accessories may be described in literature accompanying the specific products. Read and carefully follow those instructions. Such warnings and instructions are provided to assure the safe functioning of the firearm. Failure to heed them may result in improper functioning, damage to the firearm, and serious injury or death to you or others.

## **ALTERATIONS**

This SIG SAUER firearm was designed to function properly in its original condition. Unauthorized alterations can make it unsafe. Do not alter any part or add or substitute any parts or accessories not manufactured by SIG SAUER for this pistol. The addition of any parts or accessories beyond the user level of maintenance described in this manual is not authorized.



# WARNINGS

## 1.0 SAFETY WARNINGS - CONTINUED

### ACCESSORIES

It is your responsibility to ensure that all accessories, such as holsters and firearm-mounted lights, are compatible with this firearm and that the accessories do not interfere with the safe operation and handling of the firearm. If you are lawfully carrying the firearm concealed, you must ensure that the holster you choose is made for your particular firearm and designed for the type of carry in which you intend to engage.

### TRANSPORTING

When transporting your firearm, be sure the firearm is unloaded and cleared of all ammunition. It is your responsibility to familiarize yourself with the laws of any state you will be traveling through with your firearm.

### STORAGE

The only safe way to store your firearm is unloaded, cleared of all ammunition, and secure. Safe and secure storage is one of your most important responsibilities. Store your unloaded firearm separate from your ammunition and in places inaccessible to children or unauthorized persons.

### CHAMBER SAFETY FLAG

Every SIG SAUER firearm is shipped with a chamber safety flag. The chamber safety flag prevents the chambering of a round when installed and provides a readily visible indication that the firearm's chamber is empty. The chamber safety flag is to be installed in the firearm's chamber at all times when the firearm is not in use. Many public ranges require chamber safety flags be installed when the firing line is cold.



# WARNINGS

**SIG SAUER**

## LIABILITY

PISTOLS are classified as FIREARMS and are sold by SIG SAUER with the specific understanding that we shall not be responsible in any manner whatsoever for malfunctioning of the firearm, physical injury, or property damage resulting in whole or in part from:

- Criminal or negligent discharge
- Improper, careless, or abusive handling
- Unauthorized modifications or parts replacement
- Defective, improper, hand-loaded, or reloaded ammunition
- Corrosion
- Neglect
- Other influences beyond our direct and immediate control

This limitation applies regardless of whether liability is asserted on the basis of contract, negligence, or strict liability (including any failure to warn). Under no circumstance shall SIG SAUER, Inc. be liable for incidental or consequential damages such as loss of use of property, commercial loss, and loss of earnings or profits.



# WARNINGS

## BASIC RULES OF SAFE FIREARMS HANDLING

1. ALWAYS treat every firearm as if it were loaded.
2. ALWAYS be sure the barrel is clear of any obstruction.
3. ALWAYS be sure of your backstop, what lies beyond, and the safety of bystanders before you shoot.
4. ALWAYS use clean, dry, original factory-made ammunition of the proper type and caliber for your firearm.
5. ALWAYS wear ear protection and safety glasses when shooting.
6. ALWAYS carry your firearm so that you can control the direction of the muzzle if you fall or stumble.
7. NEVER shoot at a flat surface or water.
8. DO NOT leave a loaded firearm unattended. Firearms and ammunition should be stored separately, locked if possible, beyond the reach of children, careless adults, or unauthorized users.
9. NEVER allow your firearm to be used by anyone who has not read and understood this operators manual.
10. DO NOT point any firearm, loaded or unloaded, at any undesired or unsafe target.
11. NEVER discharge your firearm near an animal unless the animal is trained to accept the noise. An animal's startled reaction could injure it or cause an accident.
12. NEVER drink alcoholic beverages or use drugs before or during shooting, as your vision and judgment could be seriously impaired, making your firearm handling unsafe.





# WARNINGS

**SIG SAUER**

## 1.1 EYE AND EAR PROTECTION



Always wear safety glasses that meet the requirements of American National Standards Institute (ANSI) z87.1 and ear plugs and “ earmuff”-type protectors whenever you are shooting. Always make certain that persons close to you are similarly protected. Unprotected eyes may be injured by powder, gas, carbon residue, lubricant, metallic particles, or similar debris that may emanate occasionally from any firearm in normal use. Without ear protection, repeated exposure to shooting noise may lead to cumulative, permanent hearing loss.

## 1.2 AMMUNITION

Use only high-quality, original, factory-manufactured ammunition. Do not use cartridges that are dirty, wet, corroded, bent, or damaged. Do not oil cartridges. Do not spray aerosol-type lubricants, preservative, or cleaners directly onto cartridges or where excess spray may flow into contact with cartridges. Lubricant or other foreign matter on cartridges can cause potentially dangerous ammunition malfunctions. Use only ammunition of the caliber for which your firearm is chambered. The proper caliber is permanently engraved on your firearm; never attempt to use ammunition of any other caliber.

The use of reloaded, “re-manufactured” hand-loaded, or other nonstandard ammunition voids all warranties. Reloading is a science and improperly loaded ammunition can be extremely dangerous.



# WARNINGS

## 1.2 AMMUNITION - CONTINUED

Severe damage to the firearm and serious injury or death to the shooter or to others may result. Always use ammunition that complies with the industry performance standards established by the Sporting Arms and Ammunition Manufacturers' Institute, Inc. (SAAMI) or ammunition manufactured to U.S. military specifications.

SIG SAUER, Inc. specifically disclaims responsibility for any damage or injury whatsoever occurring in connection with, or as a result of, the use in any SIG SAUER firearm of faulty, nonstandard, "re-manufactured" hand-loaded (reloaded) ammunition, or cartridges other than those for which the firearm was originally chambered.

Firearms may be severely damaged and serious injury or death to the shooter or to others may result from any condition causing excessive pressure inside the chamber or barrel during firing. Excessive pressure can be caused by obstructions in the barrel, propellant powder overloads, the use of incorrect cartridges, or defectively assembled cartridges. In addition, the use of a dirty, corroded, or damaged cartridge can lead to a burst cartridge case and consequent damage to the firearm and personal injury from the sudden escape of high-pressure propellant gas within the firearm's mechanism.

### OBSTRUCTED BORE

Immediately stop shooting, keep the pistol pointed in a safe direction whenever:

- You have difficulty in, or feel unusual resistance in, chambering a cartridge;
- A cartridge misfires (does not go off);
- The mechanism fails to extract a fired cartridge case;
- Unburned grains of propellant powder are discovered spilled in the mechanism;
- A shot sounds weak or abnormal. It is possible that a bullet is lodged part way down the barrel.



# WARNINGS

**SIG SAUER**

- Firing a subsequent bullet into the obstructed barrel can damage the firearm and cause serious injury to the shooter or to bystanders.

Bullets can become lodged in the barrel when:

- The cartridge has been improperly loaded without propellant powder, or if the powder fails to ignite (ignition of the cartridge primer alone will push the bullet out of the cartridge case, but usually does not generate sufficient energy to expel the bullet completely from the barrel);
- The bullet is not properly seated in the cartridge case. When such a cartridge is extracted from the chamber without being fired, the bullet may be left behind in the bore at the point where the rifling begins. Subsequent chambering of another cartridge may push the first bullet further into the bore.

If there is any reason to suspect that a bullet is obstructing the barrel, immediately unload and clear the firearm. Field strip the pistol and look through the bore of the barrel. It is not sufficient to merely look in the chamber. A bullet may be lodged some distance down the barrel where it cannot easily be seen.

If a bullet is in the bore, do not attempt to shoot it out by using another cartridge or by blowing it out with a blank or a cartridge from which the bullet has been removed. Such techniques can generate excessive pressure, damage the firearm, and cause serious personal injury or death.

If the bullet can be removed by tapping it with a cleaning rod, clean any unburned powder grains from the bore, chamber, and mechanism, before resuming shooting. If the bullet cannot be dislodged by tapping it with a cleaning rod, take the firearm to a gunsmith or certified SIG SAUER Armorer.



# WARNINGS

## 1.2 AMMUNITION - CONTINUED

Dirt, corrosion, or other foreign matter on a cartridge can impede chambering and may cause the cartridge case to burst upon firing. A damaged or deformed cartridge may also impede chambering or cause the cartridge case to burst upon firing.

Do not lubricate cartridges, and be sure to wipe the chamber clean of any oil or preservative before shooting. Oil interferes with the friction between cartridge case and chamber wall that is necessary for safe functioning, and subjects the firearm to stress similar to that imposed by excessive pressure.

Use lubricants sparingly on the moving parts of your firearm. Avoid excessive spraying of any aerosol gun care product, especially where it might get on ammunition. All lubricants and aerosol spray lubricants in particular can penetrate cartridge primers and cause misfires. Some highly penetrative lubricants can also migrate inside cartridge cases and cause deterioration of the propellant powder; on firing, the powder might not ignite. If only the primer ignites, there is danger that the bullet may become lodged in the barrel.

Death, serious injury, and damage to the firearm can result from the use of wrong ammunition, bore obstructions, powder overloads, or incorrect cartridge components. Always wear shooting glasses and hearing protectors.



# WARNINGS

**SIG SAUER**



**WARNING: CANCER AND REPRODUCTIVE HARM—[www.P65warnings.ca.gov](http://www.P65warnings.ca.gov)**



DISCHARGING FIREARMS IN POORLY VENTILATED AREAS, CLEANING FIREARMS, OR HANDLING AMMUNITION MAY RESULT IN EXPOSURE TO LEAD AND OTHER SUBSTANCES KNOWN TO THE STATE OF CALIFORNIA TO CAUSE BIRTH DEFECTS, REPRODUCTIVE HARM, AND OTHER SERIOUS PHYSICAL INJURY. MAINTAIN ADEQUATE VENTILATION AT ALL TIMES. WASH HANDS THOROUGHLY AFTER EXPOSURE. SHOOTING OR CLEANING FIREARMS MAY EXPOSE YOU TO LEAD



# WARNINGS

## 1.3 STATE-BY-STATE WARNINGS

Certain states require, by law, that their own specified warning notices, in larger than-normal type be conspicuously included by the manufacturer, distributor, or retail dealer with firearms sold in that state. SIG SAUER sells its products in compliance with applicable laws and regulations. Because our products may be sold in these states, we include the following:



### **CALIFORNIA: WARNING**

Firearms must be handled responsibly and securely stored to prevent access by children and other unauthorized users. California has strict laws pertaining to firearms, and you may be fined or imprisoned if you fail to comply with them. Visit the Web site of the California Attorney General at <https://oag.ca.gov/firearms> for information on firearm laws applicable to you and how you can comply. Prevent child access by always keeping guns locked away and unloaded when not in use. If you keep a loaded firearm where a child obtains and improperly uses it, you may be fined or sent to prison."

If you or someone you know is contemplating suicide, please call the National Suicide Prevention Lifeline at 1-800-273 TALK (8255).



### **ADVERTENCIA**

Las armas de fuego deben manipularse de manera responsable y segura para evitar el acceso de niños y otros usuarios no autorizados. California tiene leyes estrictas relacionadas con armas de fuego, y usted puede ser multado o encarcelado si no las cumple. Visite el sitio web del fiscal general de California en <https://oag.ca.gov/firearms> para obtener información sobre las leyes de armas de fuego que son aplicables y cómo puede cumplirlas. Evite el acceso de niños manteniendo siempre las armas bloqueadas y descargadas cuando no estén en uso. Si mantiene un arma de fuego cargada donde un niño la puede obtener y la usa indebidamente, se le puede multar o enviar a prisión.

Si usted o alguien que conoce está contemplando el suicidio, llame a la Línea Nacional de Prevención del Suicidio al 1-800-273 TALK (8255).



# WARNINGS

**SIG SAUER**

## **CONNECTICUT:**

"UNLAWFUL STORAGE OF A LOADED FIREARM MAY RESULT IN IMPRISONMENT OR FINE."

## **FLORIDA:**

"IT IS UNLAWFUL, AND PUNISHABLE BY IMPRISONMENT AND FINE, FOR ANY ADULT TO STORE OR LEAVE A FIREARM IN ANY PLACE WITHIN THE REACH OR EASY ACCESS OF A MINOR UNDER 18 YEARS OF AGE OR TO KNOWINGLY SELL OR OTHERWISE TRANSFER OWNERSHIP OR POSSESSION OF A FIREARM TO A MINOR OR A PERSON OF UNSOUND MIND."

## **MAINE:**

"ENDANGERING THE WELFARE OF A CHILD IS A CRIME. IF YOU LEAVE A FIREARM AND AMMUNITION WITHIN EASY ACCESS OF A CHILD, YOU MAY BE SUBJECT TO FINE, IMPRISONMENT OR BOTH. KEEP FIREARMS AND AMMUNITION SEPARATE. KEEP FIREARMS AND AMMUNITION LOCKED UP. USE TRIGGER LOCKS."

## **MARYLAND:**

"WARNING: CHILDREN CAN OPERATE FIREARMS WHICH MAY CAUSE DEATH OR SERIOUS INJURY. IT IS A CRIME TO STORE OR LEAVE A LOADED FIREARM IN ANY LOCATION WHERE AN INDIVIDUAL KNEW OR SHOULD HAVE KNOWN THAT AN UNSUPERVISED MINOR WOULD GAIN ACCESS TO THE FIREARM. STORE YOUR FIREARM RESPONSIBLY!"



# WARNINGS

## MASSACHUSETTS:

“WARNING FROM THE MASSACHUSETTS ATTORNEY GENERAL: This handgun is not equipped with a device that fully blocks use by unauthorized users. More than 200,000 firearms like this one are stolen from their owners every year in the United States. In addition, there are more than a thousand suicides each year by younger children and teenagers who get access to firearms. Hundreds more die from accidental discharge. It is likely that many more children sustain serious wounds, or inflict such wounds accidentally on others. In order to limit the chance of such misuse, it is imperative that you keep this weapon locked in a secure place and take other steps necessary to limit the possibility of theft or accident. Failure to take reasonable preventative steps may result in innocent lives being lost, and in some circumstances may result in your liability for these deaths.”





# WARNINGS

**SIG SAUER**

## **MASSACHUSETTS: - Continued**

“IT IS UNLAWFUL TO STORE OR KEEP A FIREARM, PISTOL, SHOTGUN OR MACHINE GUN IN ANY PLACE UNLESS THAT WEAPON IS EQUIPPED WITH A TAMPER RESISTANT SAFETY DEVICE OR IS STORED OR KEPT IN A SECURELY LOCKED CONTAINER.”

## **NEW JERSEY:**

“IT IS A CRIMINAL OFFENSE TO LEAVE A LOADED FIREARM WITHIN EASY ACCESS OF A MINOR.”

## **NEW YORK CITY, NY:**

“THE USE OF A LOCKING DEVICE OR SAFETY LOCK IS ONLY ONE ASPECT OF RESPONSIBLE FIREARMS STORAGE. FOR INCREASED SAFETY, FIREARMS SHOULD BE STORED UNLOADED AND LOCKED IN A LOCATION THAT IS BOTH SEPARATE FROM THEIR AMMUNITION AND INACCESSIBLE TO CHILDREN AND OTHER UNAUTHORIZED PERSONS.”



# WARNINGS

## **NORTH CAROLINA:**

Any person who resides in the same premises as a minor, owns or possesses a firearm, and stores or leaves the firearm (i) in a condition that the firearm can be discharged and (ii) in a manner that the person knew or should have known that an unsupervised minor would be able to gain access to the firearm, is guilty of a Class 1 misdemeanor if a minor gains access to the firearm without the lawful permission of the minor's parents or a person having charge of the minor and the minor:

- (1) Possesses it in violation of G.S. 14-269.2(b)
- (2) Exhibits it in a public place in a careless, angry, or threatening manner;
- (3) Causes personal injury or death with it not in self defense; or
- (4) Uses it in the commission of a crime.

## **TEXAS:**

"IT IS UNLAWFUL TO STORE, TRANSPORT, OR ABANDON AN UNSECURED FIREARM IN A PLACE WHERE CHILDREN ARE LIKELY TO BE AND CAN OBTAIN ACCESS TO THE FIREARM."

## **WISCONSIN:**

"IF YOU LEAVE A LOADED FIREARM WITHIN THE REACH OR EASY ACCESS OF A CHILD YOU MAY BE FINED OR IMPRISONED OR BOTH IF THE CHILD IMPROPERLY DISCHARGES, POSSESSES, OR EXHIBITS THE FIREARM."

Please check with your licensed retailer, state police, or local police for additional warnings, which may be required by local law or regulation. Such regulations change constantly, and local authorities are in the best position to advise you on such legal matters.



# WARNINGS

**SIG SAUER**

## 1.4 LOCKING DEVICES

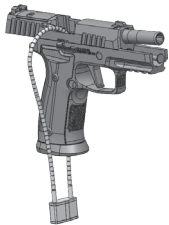

All firearms are originally shipped with a key-operated locking device, except for Custom Works firearms that are shipped with a lockable case.

Although it can help provide secure storage for your unloaded firearm, any locking device can fail.

All firearms are designed to fire if they are loaded and the trigger is pressed.

Therefore, never install the locking device inside the trigger guard or in any way that makes it possible to press the trigger! Do not leave the keys in the lock.

The ultimate responsibility for secure storage of any firearm must depend upon its owner and his or her individual circumstances.

Firearms should be stored unloaded, in a secure location, separate from their ammunition.

To maximize effectiveness and reduce the chances of malfunction or damage to a firearm, ALWAYS refer to the locking device's manufacturer directions for installation and removal of the device.



# WARNINGS

## 1.5 SAFETY INFORMATION

This operator's manual is designed to assist you in learning how to use and care for your SIG SAUER® firearm properly.

Only when you are certain that you fully understand this manual and can properly carry out its instructions, should you practice loading and firing your firearm with live ammunition. Having a firearm in your possession is a full-time job; you cannot guess and you cannot forget. You must know how to use your firearm safely.

If you have any doubts about your ability to handle or use this firearm safely, you should seek supervised instruction.

The SIG SAUER Academy provides all levels of firearms safety and skill training, from beginner to expert.

For more information contact:

**SIG SAUER**<sup>®</sup>  
**ACADEMY**

sigsaueracademy.com • (603) 610-3400  
Epping, New Hampshire

**SAFETY MUST BE THE FIRST AND CONSTANT CONSIDERATION OF EVERY PERSON WHO HANDLES FIREARMS AND AMMUNITION.**

For more information about safety, responsible firearms ownership, and shooting sports, contact:  
National Rifle Association (NRA) of America  
11250 Waples Mill Road, Fairfax, VA 22030-7400 • 1-800-672-3888  
nra.com

**THIS PAGE INTENTIONALLY LEFT BLANK**



## Contents

1.0 SAFETY WARNINGS . . . . .	2
1.1 EYE AND EAR PROTECTION . . . . .	9
1.2 AMMUNITION . . . . .	9
1.3 STATE-BY-STATE WARNINGS. . . . .	14
1.4 LOCKING DEVICES . . . . .	19
1.5 SAFETY INFORMATION . . . . .	20
2.0 MECHANICAL CHARACTERISTICS AND THEORY . . . . .	24
2.1 DESCRIPTION OF FIREARM . . . . .	24
2.2 MAIN COMPONENTS AND OPERATOR CONTROLS . . . . .	26
3.0 HANDLING . . . . .	28
3.1 PREPARATION INSTRUCTIONS . . . . .	28
3.2 MANUAL SAFETY . . . . .	28
3.3 LOADING THE MAGAZINE . . . . .	30
3.4 LOADING THE PISTOL (READY TO FIRE). . . . .	32
3.5 RELOADING DURING SHOOTING (MAGAZINE DEPLETED) . . . . .	36
3.5 RELOADING DURING SHOOTING (PARTIAL MAGAZINE) . . . . .	42
4.0 FIRING. . . . .	45
4.1 STOPPAGES AND MALFUNCTIONS . . . . .	46
4.2 MINIMIZING STOPPAGES . . . . .	47
4.3 FIRING THE PISTOL . . . . .	48
5.0 UNLOADING THE PISTOL . . . . .	50
5.1 UNLOADING THE PISTOL MAGAZINE (NOT EMPTY) . . . . .	51
5.2 UNLOADING THE PISTOL (MAGAZINE EMPTY, SLIDE OPEN) . . . . .	54
5.3 UNLOADING THE PISTOL FOR STORAGE . . . . .	56
6.0 TROUBLESHOOTING GUIDE . . . . .	57
7.0 MAINTENANCE . . . . .	59
7.1 PISTOL DISASSEMBLY . . . . .	59
7.2 MAGAZINE DISASSEMBLY . . . . .	66
7.3 CLEANING AND LUBRICATING . . . . .	70

7.4 PISTOL ASSEMBLY . . . . .	75
7.5 MAGAZINE ASSEMBLY . . . . .	81
7.6 FUNCTION CHECK . . . . .	83
8.0 MAGAZINE CATCH REMOVAL AND REVERSAL . . . . .	85
8.1 MAGAZINE CATCH REMOVAL . . . . .	86
8.2 MAGAZINE CATCH INSTALLATION . . . . .	88
8.3 MAGAZINE FUNNEL REMOVAL AND INSTALLATION . . . . .	90
9.0 SIGHTS . . . . .	92
9.1 GENERAL INFORMATION . . . . .	94
9.2 SIGHT ADJUSTMENT . . . . .	94
10.0 TRIGGER ADJUSTMENT . . . . .	97
10.1 REACH ADJUSTMENT . . . . .	97
10.2 TRIGGER PULL WEIGHT ADJUSTMENT . . . . .	98
10.3 TRIGGER OVERTRAVEL ADJUSTMENT . . . . .	99
10.4 TRIGGER SHOE REMOVAL AND INSTALLATION . . . . .	100
10.5 SIGHT PLATE REMOVAL AND INSTALLATION . . . . .	102
10.6 ROMEO INSTALLATION . . . . .	104
11.0 STORAGE AND TRANSPORTATION . . . . .	106
11.1 STORAGE . . . . .	106
11.2 TRANSPORTATION . . . . .	108
12.0 PARTS POLICY . . . . .	109
13.0 SERVICE POLICY . . . . .	110
14.0 SHIPPING FIREARMS FOR REPAIR . . . . .	111
15.0 STANDARD SLIDE PARTS DIAGRAM . . . . .	113
15.1 FRAME DIAGRAM . . . . .	114
16.0 TECHNICAL SPECIFICATIONS . . . . .	115



## **2.0 MECHANICAL CHARACTERISTICS AND THEORY**

### **2.1 DESCRIPTION OF FIREARM**

#### **2.1.1 GENERAL**

The SIG SAUER P226 XFIVE pistol is a modern optics-ready handgun that incorporates the latest technical advances in firearm design for military, law enforcement, and sporting use. P226 pistols are mechanically locked, short-recoil-operated pistols with semiautomatic reloading. Firing takes place with each press of the trigger until the magazine is empty. The slide remains open after the last round has been fired from the magazine.

#### **2.1.2 PRINCIPAL FEATURES**

The SIG SAUER P226 XFIVE pistols incorporate multiple safety features including the automatic firing pin safety lock and ambidextrous manual safety.

Distinctive fiber optic sights, in conjunction with the ergonomically correct grip, ensure rapid target acquisition and engagement, even under poor lighting conditions.



P226 XFIVE pistols are compatible with SIG SAUER Electro Optics, that use the Romeo1PRO/ Romeo2 footprint.

The magazine catch can be set up for left or right hand operation.

A MIL-STD 1913 rail is integrated into the frame, facilitating the easy attachment of industry standard tactical accessories.

The closed design of the pistol helps keep dirt and other debris from entering the pistol, improving function in harsh environmental conditions.

The SIG SAUER P226 XFIVE pistol is currently offered in Single Action Only (SAO).

Manual safeties are ambidextrous and can be operated from either side of the pistol.

The P226 XFIVE pistol is equipped with a 3-way adjustable AX3 trigger, allowing individual adjustments for trigger reach, weight, and overtravel.

P226 XFIVE pistols are equipped with fiber optic sights and low profile controls. Also available are co-witnessing backup sights in multiple heights, including silencer or optic compatible sights.



## 2.2 MAIN COMPONENTS AND OPERATOR CONTROLS



LEFT SIDE



RIGHT SIDE

**TABLE 1. OPERATOR CONTROLS AND FEATURES**

Number	Item Name	Description
1	Front Sight	The means of aiming the pistol.
2	Slide	Houses extractor, firing pin safety lock, firing pin and sights.
3	Take Down Lever	Holds the slide and barrel to the frame.
4	Slide Catch Lever	Locks slide to rear upon firing of last cartridge. Can be used to manually lock slide to rear for maintenance.
5	Rear Sight	The means of aiming the pistol.
6	Manual Safety Lever	When engaged, prevents the trigger bar from releasing the sear when the hammer is cocked and the trigger is pressed.
7	Hammer	Impacts the firing pin, causing it to detonate the primer.
8	Extractor	Pulls spent casings or cartridges out of the chamber of the barrel.
9	Barrel	Houses cartridge for firing and directs projectile.
10	Frame	Supports all major components of pistol. Includes integrated MIL-STD 1913 rail.
11	Trigger	When pressed actuates the internal components to release the hammer.
12	Magazine	Holds and positions cartridges in place for feeding.
13	Magazine Catch	Locks magazine into frame. Releases magazine when pressed. Can be configured for left or right hand user.



## 3.0 HANDLING

### 3.1 PREPARATION INSTRUCTIONS

Prior to firing the pistol for the first time, we strongly suggest that you perform an initial cleaning and lubrication of the pistol after you unpack it. Any fouling present will have been from final range firing at the factory prior to shipping.

Refer to section, “7.3 Cleaning And Lubricating” on page 70 for instructions pertaining to cleaning the pistol.

If you have the pistol, the correct ammunition, and have read and understood all of the safety instructions, you are now ready to use the pistol.

### 3.2 MANUAL SAFETY

The SIG SAUER P226 XFIVE pistol is equipped with an ambidextrous manual safety. The manual safety is designed to block the movement of the trigger bar, preventing it from moving the sear and releasing the hammer.



**WARNING**

**SAFETY**



**THE MANUAL SAFETY CANNOT BE ENGAGED OR DISENGAGED AFTER THE SLIDE IS LOCKED TO THE REAR. THE MANUAL SAFETY CAN BE ENGAGED WHEN THE SLIDE IS FORWARD. ONCE THE MANUAL SAFETY IS ENGAGED, THE SLIDE CAN BE CYCLED BY HAND.**

To engage the manual safety, rotate the manual safety lever upward. The manual safety is ambidextrous and when one lever is rotated the opposite lever is also rotated. There should be an audible click when engaging or disengaging the manual safety. You can still manipulate the slide with the manual safety engaged. To disengage the manual safety, push down on the manual safety lever and both levers will rotate down to disengage the manual safety.

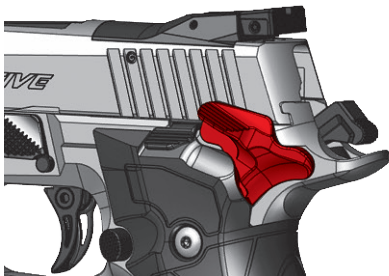

LEFT SIDE MANUAL SAFETY ENGAGED

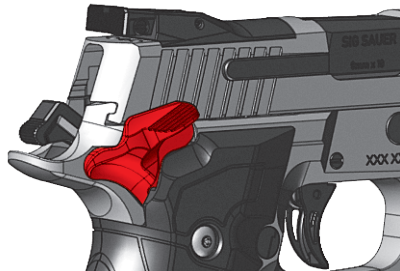

RIGHT SIDE MANUAL SAFETY ENGAGED



### 3.3 LOADING THE MAGAZINE

#### NOTE

Ensure that the magazine and ammunition is the proper type and caliber for the pistol.

1. Press down on magazine follower using cartridge case rim. Ensure that bullet is facing front of magazine.
2. Push cartridge to the rear and under magazine lips.

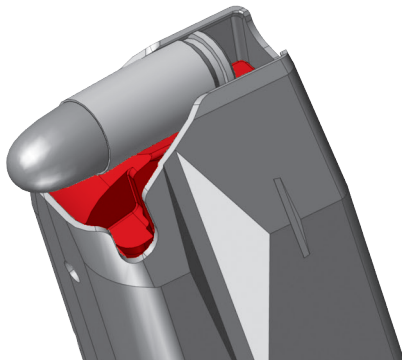

3. Repeat until magazine holds the desired number of cartridges or it is full. Do not attempt to insert more cartridges than the magazine's designed capacity. The capacity of the 17 round magazine with extended, alloy basepad is 20 rounds.

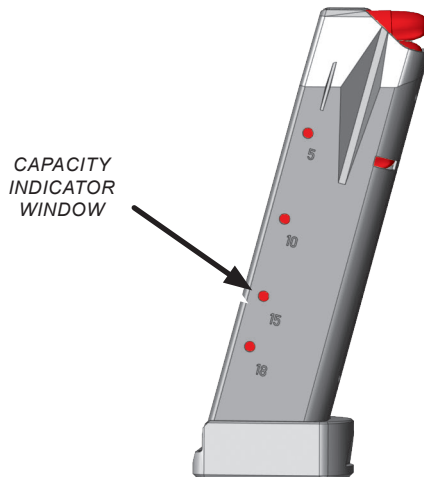



### 3.4 LOADING THE PISTOL (READY TO FIRE)

1. Keep muzzle pointed in a safe direction and engage manual safety.
2. Fully retract slide and lock it to the rear by pushing up on slide catch lever.

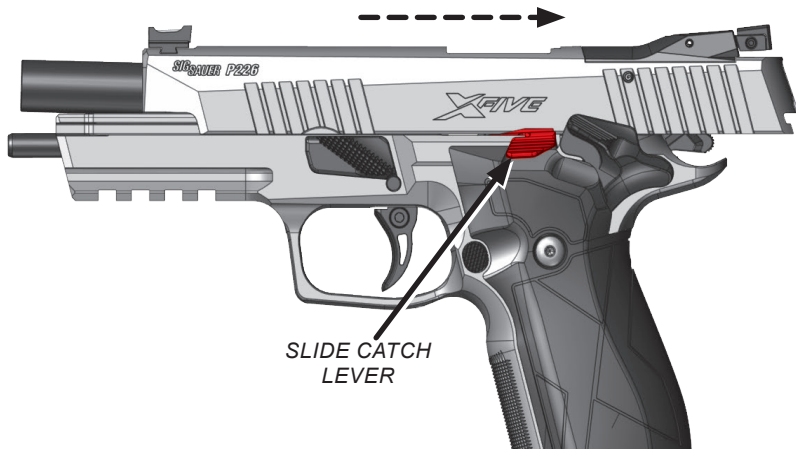



3. Visually and physically inspect the chamber, breech face and magazine well to ensure it is clear of ammunition and foreign debris.

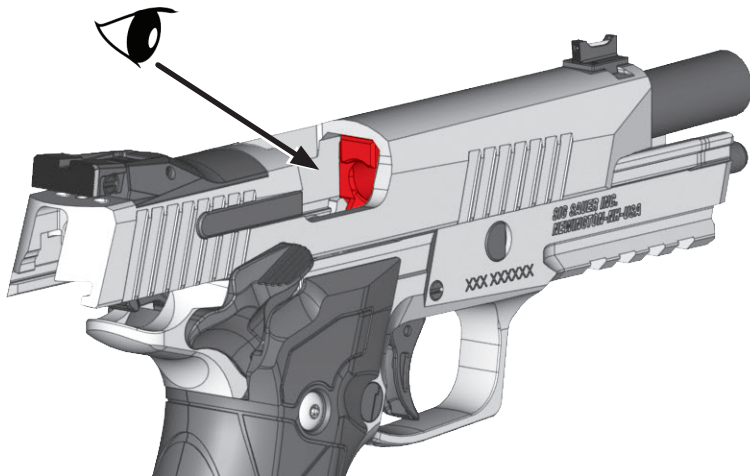



### 3.4 LOADING THE PISTOL (READY TO FIRE) - CONTINUED

4. Insert a loaded magazine by, pushing it up into frame until it locks in place. You should hear an audible click.

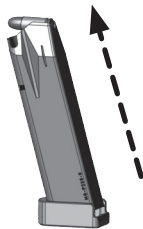

**CAUTION**

DO NOT RIDE THE SLIDE FORWARD. FAILURE TO PROPERLY COMPLETE STEP 5 (b ) MAY INDUCE A STOPPAGE.

5. To chamber a cartridge release the slide by either:
  - a. Pressing down on slide catch lever.
  - b. Pulling back on the slide until slide catch lever drops clear of slide then, releasing the slide.

**WARNING****LOADED PISTOL**

**THE PISTOL IS NOW LOADED AND READY TO FIRE.**



### 3.4 LOADING THE PISTOL (READY TO FIRE) - CONTINUED



**WARNING**

**SAFETY**



**DO NOT ATTEMPT TO LOWER THE HAMMER OF THIS PISTOL WITH A LIVE CARTRIDGE IN THE CHAMBER BY PRESSING THE TRIGGER AND EASING THE HAMMER FORWARD. MANUALLY LOWERING THE HAMMER IN THIS MANNER PREVENTS THE FULL APPLICATION OF THE SAFETY FEATURES OF THIS PISTOL. FAILURE TO COMPLY WITH THIS WARNING COULD CAUSE AN UNINTENTIONAL DISCHARGE RESULTING IN DEATH, SERIOUS INJURY, OR DAMAGE TO PROPERTY.**

### 3.5 RELOADING DURING SHOOTING (MAGAZINE DEPLETED)

#### **NOTE**

Upon firing the last round in the pistol, the empty magazine will engage the slide catch lever and lock slide in the open position.

1. Keep the muzzle pointed in a safe direction.
2. Press magazine catch to release the empty magazine.

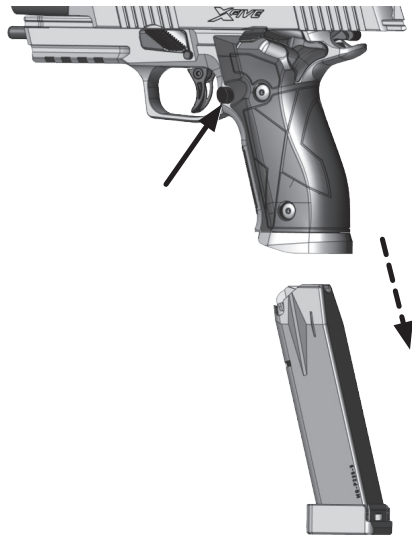



### 3.5 RELOADING DURING SHOOTING (MAGAZINE DEPLETED) - CONTINUED

3. Insert a loaded magazine by, pushing it up and into the frame until it locks in place. You should hear an audible click.

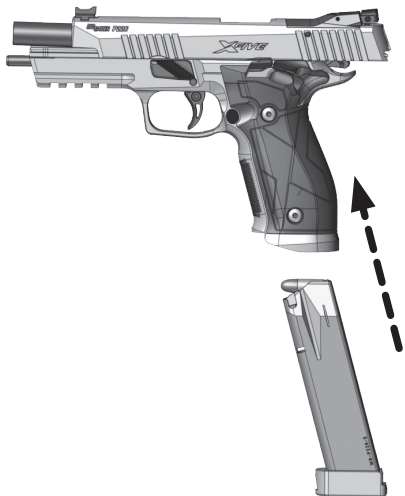

**CAUTION**

DO NOT RIDE THE SLIDE FORWARD. FAILURE TO PROPERLY COMPLETE STEP 4 (b) MAY INDUCE A STOPPAGE.

4. To chamber a round, release the slide by either:
  - a. Pressing down on slide catch lever.
  - b. Pulling back on the slide until slide catch lever drops clear of the slide then, releasing slide.





### 3.5 RELOADING DURING SHOOTING (MAGAZINE DEPLETED) - CONTINUED

5. Rotate the manual safety lever upward to engage manual safety.



**WARNING**

**LOADED PISTOL**



**THE PISTOL IS NOW LOADED AND READY TO FIRE.**



**WARNING****SAFETY**

**DO NOT ATTEMPT TO LOWER THE HAMMER OF THIS PISTOL WITH A LIVE CARTRIDGE IN THE CHAMBER BY PRESSING THE TRIGGER AND EASING THE HAMMER FORWARD. MANUALLY LOWERING THE HAMMER IN THIS MANNER PREVENTS THE FULL APPLICATION OF THE SAFETY FEATURES OF THIS PISTOL. FAILURE TO COMPLY WITH THIS WARNING COULD CAUSE AN UNINTENTIONAL DISCHARGE RESULTING IN DEATH, SERIOUS INJURY, OR DAMAGE TO PROPERTY**

**NOTE**

Upon firing the last round in the magazine, the magazine follower will push up on the slide catch lever locking the slide to the rear.



### 3.5 RELOADING DURING SHOOTING (PARTIAL MAGAZINE)

## NOTE

A magazine does not need to be empty to be removed.

1. Keep the muzzle pointed in a safe direction.
2. Rotate the manual safety lever upward to engage manual safety.



3. Press magazine catch to remove the partially loaded magazine.



**WARNING**

**LOADED PISTOL**



**THE PISTOL STILL HAS A LIVE CARTRIDGE CHAMBERED AND CAN BE FIRED IF THE MANUAL SAFETY IS DISENGAGED AND THE TRIGGER IS PRESSED.**



### 3.5 RELOADING DURING SHOOTING (PARTIAL MAGAZINE) - CONTINUED

4. Insert a loaded magazine by, pushing it up and into the magazine well until it locks in place. You should hear an audible click.

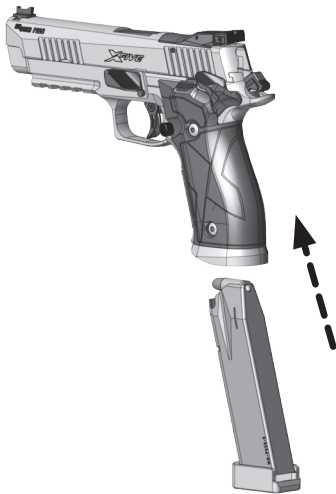

## 4.0 FIRING



**WARNING**

**LOADED PISTOL**



**KEEP FINGER OUT OF TRIGGER GUARD AND OFF TRIGGER UNTIL YOU ARE ACTUALLY READY TO FIRE THE PISTOL.**

Keep the muzzle pointed in a safe direction, your finger off of the trigger and out of the trigger guard when cycling the slide of any pistol.

Never discharge any firearm with your finger, hand, face, or other part of your body over or adjacent to the ejection port, or in any position where you may be struck by the reciprocating movement of the slide. Both the ejection of empty cartridge cases and the movement of the slide are part of the normal operating cycle of firearms and pose no safety hazard to the shooter if the firearm is held in a normal grip and fired at arm's length.

Never allow other persons to stand beside you where they might be struck by an ejected cartridge case. The case is hot and may be ejected with sufficient force to cause a burn, cut, or other injury. Wear safety glasses to protect your eyes. Make certain that there is a clear, unobstructed path for safe ejection of the fired case. Remember, the case might bounce off a hard object nearby and strike you or someone else.



## 4.1 STOPPAGES AND MALFUNCTIONS



**WARNING**

**STOPPAGE**



### **STOP SHOOTING IMMEDIATELY! UNLOAD AND CLEAR THE FIREARM.**

A stoppage is defined as an interruption in the pistols cycle of function that can be cleared by the operator applying immediate action. Immediate action are the steps taken by the operator to place the pistol back in service without investigating the cause of the stoppage. When practical, always stop shooting and investigate the cause of a stoppage in the manner outlined below.

If while shooting, your firearm develops a stoppage, or a discharged round sounds or feels unusual, stop shooting immediately. It may be dangerous to continue. Do not try one more shot. Keep the firearm pointed in a safe direction, engage manual safety, unload and clear the firearm immediately by removing the magazine, locking the slide to the rear and clearing any expended or live ammunition from the firearm, visually and physically checking the chamber, breech face, and magazine well.

With the firearm unloaded and cleared, perform an additional visual inspection of the firearm and the ammunition. If you suspect a bore obstruction, refer to Section 1.2 AMMUNITION - OBSTRUCTED BORE. If damage to the firearm is found upon inspection, the stoppage persists or a malfunction (defined as a failure of a part rendering the firearm inoperable and requiring the service of an authorized SIG SAUER Armorer) is suspected, take the firearm and ammunition to a certified SIG SAUER Armorer for service.

**WARNING****COOK-OFF**

**IF YOUR PISTOL STOPS FIRING WITH A LIVE ROUND IN THE CHAMBER OF A HOT BARREL (A MISFIRE OR STOPPAGE), REMOVE THE ROUND IMMEDIATELY. IF YOU CANNOT REMOVE THE ROUND WITHIN 10 SECONDS, REMOVE THE MAGAZINE AND WAIT AT LEAST 15 MINUTES WITH THE PISTOL POINTING IN A SAFE DIRECTION. THIS WAY, NEITHER THE USER NOR ANY OTHER PERSON WOULD BE INJURED BY THE POSSIBILITY OF A ROUND “COOKING-OFF” (A ROUND DETONATING DUE TO THE HEAT OF THE BARREL). KEEP YOUR FACE AWAY FROM THE EJECTION PORT WHILE CLEARING A HOT CHAMBER**

## **4.2 MINIMIZING STOPPAGES**

- You can help minimize most stoppages by cleaning and lubricating the pistol (see Section 7.3 “Cleaning and Lubricating”).
- Cleaning and lubricating your pistol after each range session will reduce the chances of a stoppage due to dirt and residue buildup.
- Perform maintenance if the firearm is exposed to extreme environmental conditions (rain, snow, freezing temperatures, etc.).
- Periodically inspect the pistol if it is to be stored for extended periods of time without use. Most stoppages are directly related to the magazine. Perform maintenance of your magazines as well as the firearm (see Section. 7.2 “Magazine Disassembly”).
- A good practice is to mark the magazines so you can identify a magazine that is related to a stoppage.



### 4.3 FIRING THE PISTOL



**WARNING**

**EJECTION**



**THE SLIDE OPENS AND SHUTS QUICKLY WHILE FIRING. KEEP FACE AND HANDS AWAY FROM IT. HOT BRASS, UNBURNT POWDER, AND GAS IS EJECTED QUICKLY AND CAN BURN YOU. ALWAYS WEAR SAFETY GLASSES AND HEARING PROTECTION.**



1. Aim the pistol at a safe target.
2. Push down on the manual safety lever to disengage manual safety.
3. Press the trigger rearward to discharge.
4. Keep the pistol aimed at target and continue to fire as desired or until magazine is empty.



**WARNING****SAFETY**

**DO NOT ATTEMPT TO LOWER THE HAMMER OF THIS PISTOL WITH A LIVE CARTRIDGE IN THE CHAMBER BY PRESSING THE TRIGGER AND EASING THE HAMMER FORWARD. MANUALLY LOWERING THE HAMMER IN THIS MANNER PREVENTS THE FULL APPLICATION OF THE SAFETY FEATURES OF THIS PISTOL. FAILURE TO COMPLY WITH THIS WARNING COULD CAUSE AN UNINTENTIONAL DISCHARGE RESULTING IN DEATH, SERIOUS INJURY, OR DAMAGE TO PROPERTY**

5. Rotate the manual safety lever upward to engage manual safety.
6. To unload and clear proceed to section, "5.0 Unloading the pistol" on page 50.



## 5.0 UNLOADING THE PISTOL



**WARNING**

**UNLOAD/CLEAR**



**WHEN THERE IS A CARTRIDGE IN THE CHAMBER, THE CARTRIDGE WILL DISCHARGE IF THE MANUAL SAFETY IS DISENGAGED AND THE TRIGGER IS PRESSED. IT IS ABSOLUTELY ESSENTIAL FOR THE USER TO KNOW HOW TO COMPLETELY UNLOAD AND CLEAR THE PISTOL. "COMPLETLEY" MEANS REMOVING THE SOURCE OF AMMUNITION, REMOVING A CHAMBERED CARTRIDGE, VISUALLY AND PHYSICALLY CHECKING THE CHAMBER, BREECH FACE, AND MAGAZINE WELL, AND UNLOADING THE MAGAZINE. A PISTOL WILL FIRE A CHAMBERED CARTRIDGE EVEN WITH THE MAGAZINE REMOVED.**

1. Always make sure the muzzle is pointed in a safe direction! Remember to clear the chamber after the magazine has been removed.
2. Never assume that any firearm is unloaded until you have personally checked it, visually and physically!
3. After every range session, make a final check to be certain the firearm is unloaded before leaving the range.

## 5.1 UNLOADING THE PISTOL MAGAZINE (NOT EMPTY)

1. Keep the muzzle pointed in a safe direction.
2. Rotate the manual safety lever upward to engage manual safety.
3. Press magazine catch and remove magazine.
4. Pull the slide completely to the rear while watching for the ejection of a live cartridge and push up on the slide catch lever, to lock slide open.





## 5.1 UNLOADING THE PISTOL MAGAZINE (NOT EMPTY) - CONTINUED

5. Visually and physically check the chamber, breech face, and magazine well to ensure that the pistol is completely free of ammunition.

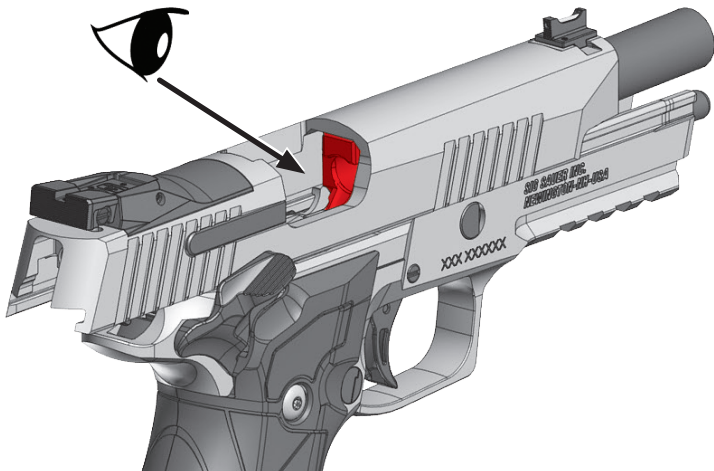

6. Release the slide by either:
  - a. Pressing down on the slide catch lever.
  - b. Pulling back on the slide until slide catch lever drops clear of the slide then, releasing slide.



7. Keep the muzzle pointed in a safe direction.
8. Unload magazine.



## 5.2 UNLOADING THE PISTOL (MAGAZINE EMPTY, SLIDE OPEN)

1. Keep the muzzle pointed in a safe direction.
2. Press magazine catch and remove magazine.
3. Visually and physically check the chamber, breech face, and magazine well to ensure that the pistol is completely free of ammunition.

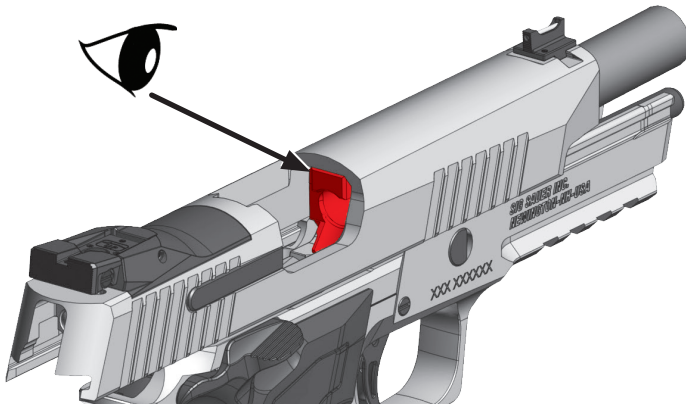

4. Release the slide by either:
  - a. Pressing down on slide catch lever.
  - b. Pulling back on the slide until slide catch lever drops clear of the slide then, releasing slide.



5. Rotate the manual safety lever upward to engage manual safety.
6. Keep the muzzle pointed in a safe direction.
7. Unload the magazine.



### **5.3 UNLOADING THE PISTOL FOR STORAGE**

The pistol should not be stored unloaded with the hammer cocked.

Complete the unloading procedure from sections 5.1 or 5.2 depending on the condition of your pistol.

Once you have unloaded and cleared the pistol and magazine and have absolutely confirmed the pistol is safe, point the pistol in a safe direction, disengage the manual safety and press the trigger to lower the hammer.



## 6.0 TROUBLESHOOTING GUIDE

Always unload and clear the pistol prior to investigating and correcting any of the issues listed in this section.

<b>Stoppage</b>	<b>Possible Cause</b>	<b>Possible Correction</b>
<b><i>Failure to Feed</i></b>		
Cartridge not fed into chamber. Partially in magazine	Magazine not properly seated	Remove, reinstall, attempt to fire
	Damaged magazine	Replace magazine
	Slide motion impeded during firing	Ensure that hands and/or foreign objects are not restricting slide motion
<b><i>Failure to Chamber</i></b>		
Cartridge free from magazine but not fully seated in chamber	Dirty chamber	Clean pistol
	Damaged/Dirty ammunition	Replace ammunition



## 6.0 TROUBLESHOOTING GUIDE - CONTINUED

Stoppage	Possible Cause	Possible Correction
<b>Failure to Fire</b>		
Trigger is pressed but cartridge does not detonate	Faulty ammunition	Replace ammunition
	Slide not fully locked forward	Ensure slide is fully forward
	Broken internal component	Return pistol to SIG SAUER for repair
<b>Failure to Extract</b>		
Expended cartridge case still in chamber	Dirty chamber	Clean pistol
	Broken extractor	Return pistol to SIG SAUER for repair
<b>Failure to Eject</b>		
Expended cartridge case stuck in ejection port	Weak/underpowered ammunition	Change ammunition
	Slide motion impeded during firing	Ensure that hands and/or foreign objects are not restricting slide motion
	Relaxed grip	Increase grip on pistol
	Broken internal component	Return pistol to SIG SAUER for repair

## 7.0 MAINTENANCE

**WARNING****UNLOAD/CLEAR**

**VERIFY THAT THE MAGAZINE IS REMOVED, VISUALLY AND PHYSICALLY CONFIRM THAT THE PISTOL IS UNLOADED AND CLEARED BEFORE ATTEMPTING DISASSEMBLY OR PERFORMING ANY MAINTENANCE STEPS. FAILURE TO ENSURE THAT THE FIREARM IS UNLOADED AND CLEARED COULD RESULT IN UNINTENTIONAL DISCHARGE, CAUSING SEVERE INJURY OR DEATH, OR PROPERTY DAMAGE. VERIFY THAT THE FIREARM IS UNLOADED AND CLEARED.**

### **NOTE**

Replace the recoil spring and buffer spring every 5,000 rounds. Refer to Section 7.4 Step 3.

## 7.1 PISTOL DISASSEMBLY

1. Unload and clear the pistol see, “5.0 Unloading the pistol” on page 50.
2. The SIG SAUER P226XFIVE is available with a sport takedown lever. If your model does not have the sport takedown lever, proceed to Step 3.
  - a. Release the slide forward by either:
    - Pressing down on slide catch lever.
    - Pull back on the slide until slide catch lever drops clear of the slide, releasing the slide.
    - Ensure manual safety is engaged.



## 7.1 PISTOL DISASSEMBLY - CONTINUED

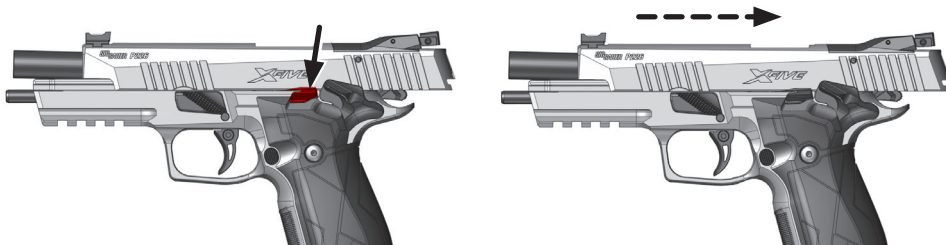

- b. With slide in battery, rotate the takedown lever counterclockwise slightly.

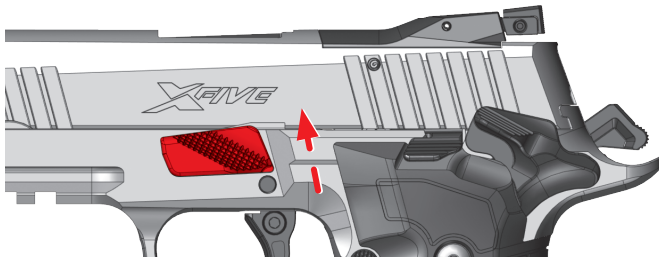

c. While holding the takedown lever in this position, push the trigger pin in, flush with the frame.

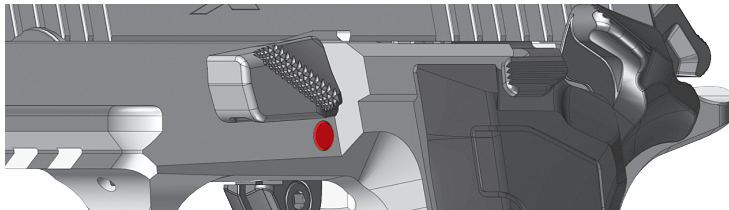

3. Lock the slide to the rear by pulling slide rearward and pushing up on slide catch lever.

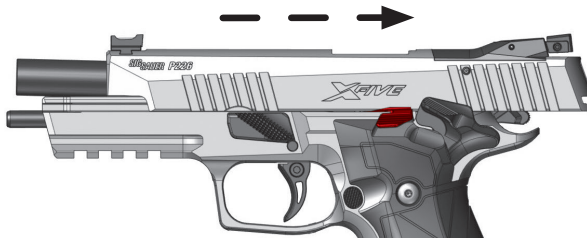



## 7.1 PISTOL DISASSEMBLY - CONTINUED

4. Rotate takedown lever clockwise until it stops.

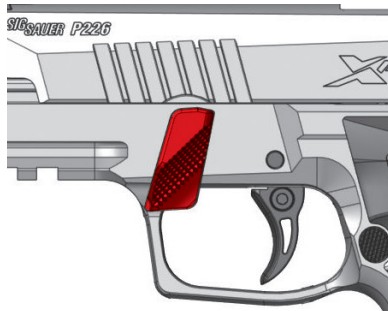

**WARNING PARTS UNDER SPRING TENSION**



**SLIDE IS UNDER SPRING TENSION. MAINTAIN POSITIVE CONTROL DURING SLIDE REMOVAL TO PREVENT DAMAGE OR INJURY. WEAR EYE PROTECTION**

5. Pull back the slide slightly to disengage the slide catch lever. Hold the slide firmly and allow it to

- move forward slowly.
- Now slip the complete assembly (comprised of slide, barrel, recoil spring and guide rod) forward and off the frame.
  - Should you need any further support in disassembling your pistol, please call our Customer Service Department at (603) 610-3000 ext 3

**WARNING PARTS UNDER SPRING TENSION**

**THE RECOIL SPRING AND GUIDE ARE UNDER SPRING TENSION AND NOT FIRMLY ATTACHED TO THE SLIDE. USE CAUTION TO PREVENT INJURY OR DAMAGE TO THE PISTOL. WEAR EYE PROTECTION.**

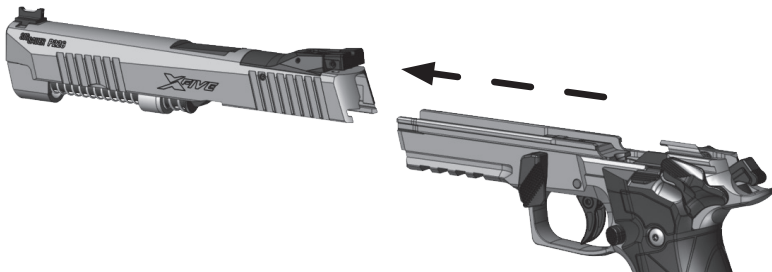



## 7.1 PISTOL DISASSEMBLY - CONTINUED



**WARNING PARTS UNDER SPRING TENSION**



8. Push the recoil guide forward slightly and lift it from rear to remove the recoil spring and guide from the slide.

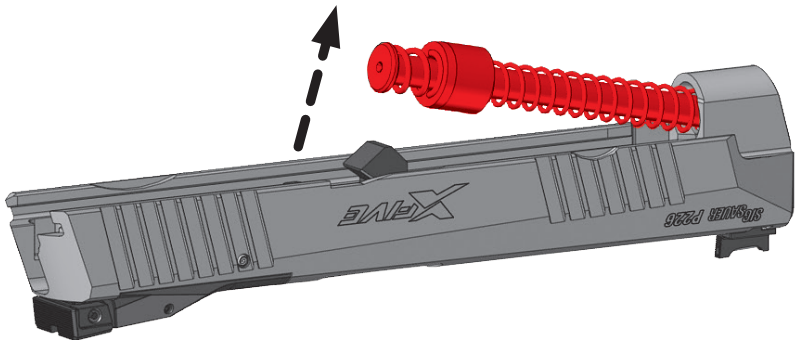



9. Remove the barrel from the slide by pulling upward slightly and to the rear.

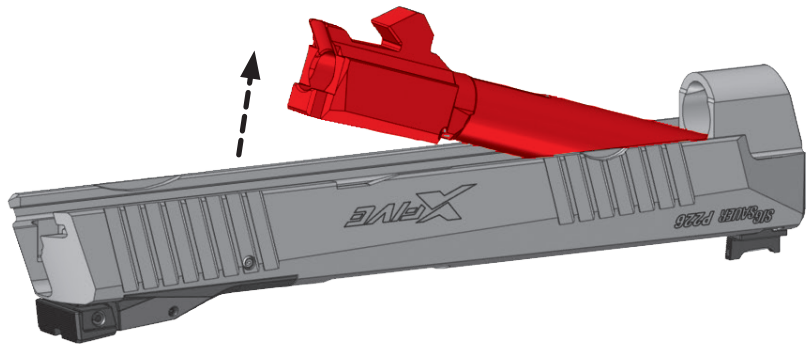

## NOTE

This level of disassembly is sufficient to allow a thorough cleaning after firing.



## 7.2 MAGAZINE DISASSEMBLY

1. Locate the bottom of magazine floor plate.

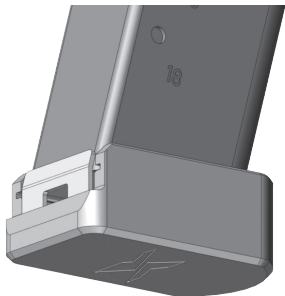

**WARNING PARTS UNDER SPRING TENSION**



**THE MAGAZINE SPRING IS COMPRESSED. GUARD THE MAGAZINE INSERT AND MAGAZINE SPRING. UNCONTROLLED RELEASE CAN CAUSE INJURY. WEAR EYE PROTECTION.**

**WARNING PARTS UNDER SPRING TENSION**

Using the notch in the inner plate, push up on the magazine insert.

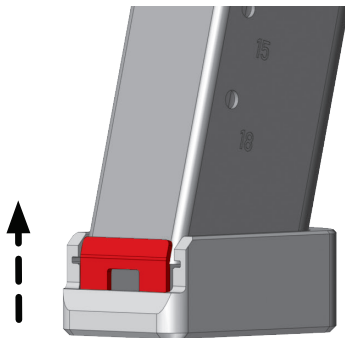



## 7.2 MAGAZINE DISASSEMBLY - CONTINUED

2. Slide the floor plate off of the magazine tube.

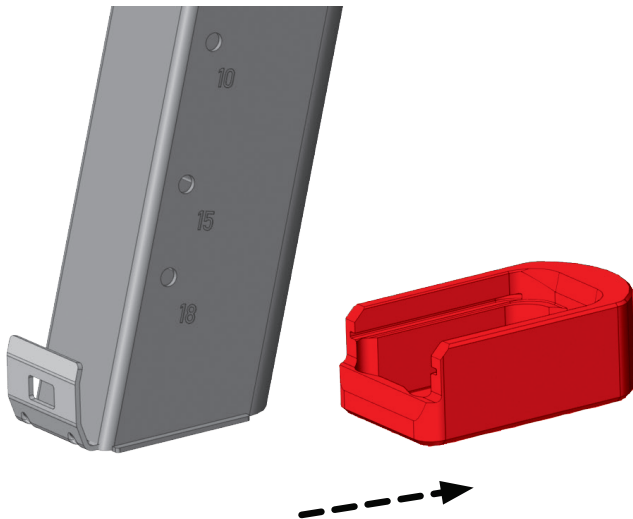

3. Remove magazine spring and magazine follower from magazine tube.

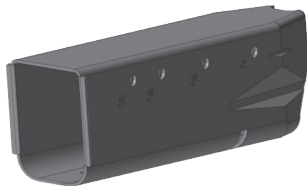
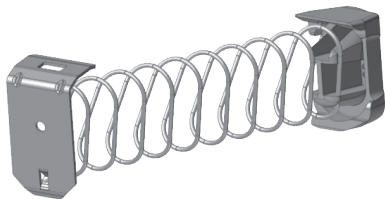



## 7.3 CLEANING AND LUBRICATING



**WARNING CLEANING**



**READ AND FOLLOW THE MANUFACTURER'S WARNINGS BEFORE USING SOLVENTS OR CLEANERS. WEAR EYE PROTECTION.**

## CAUTION

NEVER CLEAN THE BARREL FROM THE MUZZLE END, CLEANING FROM THE MUZZLE END COULD CAUSE DAMAGE TO THE CROWN OR THE RIFLING OF THE BARREL; DO NOT USE A STEEL WIRE BRUSH AS IT CAN DAMAGE THE SMOOTH SURFACE OF THE BARREL. USE A SUITABLE CLEANING ROD AND BRONZE BRUSH OF THE CORRECT CALIBER. SOLVENTS CAN BE HARMFUL TO THE SURFACE FINISH OF THE PISTOL. AVOID OVER-LUBRICATION OF COMPONENTS.

**CAUTION**

DO NOT LUBRICATE THE FIRING PIN. THIS MAY CAUSE A LIGHT STRIKE TO THE CARTRIDGE RESULTING IN A FAILURE TO FIRE.

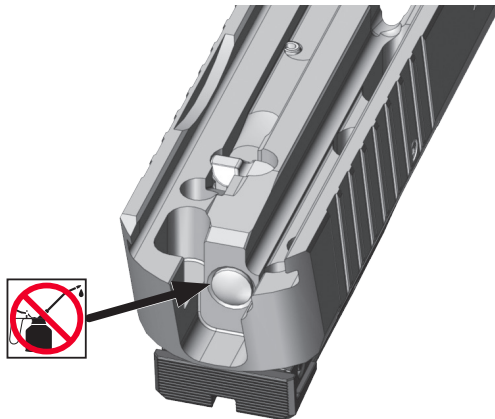



## 7.3 CLEANING AND LUBRICATING - CONTINUED

### MATERIALS REQUIRED

- Cleaning patches
- Rag, wiping
- Bore brush of the proper caliber
- Cleaning rod
- CLP (Cleaning, Lubricant, Protective)
- Lubricant, Low Temperature when applicable
- Brush, cleaning

The following instructions are for normal environmental conditions. Clean and lube before or after every time the pistol is fired or at a minimum of every 500 rounds.

### SLIDE ASSEMBLY

1. Remove all of the old lubricant before you reapply.
2. Clean the slide assembly with a cloth. A soft brush and CLP can be used to clean excessive dirt and carbon buildup. Ensure the extractor, rail slots and breech face are free of dirt and residue.
3. Apply a light coat of CLP to the frame rail slots of the slide.
4. Lightly oil all external parts.
5. Do not lubricate the firing pin.



## BARREL

1. Soak a patch with CLP and push it through the bore from the chamber end and out past the muzzle.
2. Allow the CLP to soak for a while to loosen residue and soften carbon deposits.
3. Wipe the exterior of the barrel with a cloth soaked in CLP.
4. Repeat step #1.
5. Use the bore brush and a cleaning rod to scrub heavy deposits from the bore.
6. Repeat step #1.
7. Push dry patches through the bore until they come out clean.
8. Lightly oil bore and chamber if the pistol is to be stored for a period of time.
9. Always remove any lubricant from the bore prior to firing the pistol.

## RECOIL SPRING AND GUIDE

### CAUTION

1. Clean the recoil spring guide with CLP and a soft brush.
2. After cleaning, apply a light coat of CLP.



## 7.3 CLEANING AND LUBRICATING - CONTINUED

### FRAME ASSEMBLY

1. Wipe the frame with a soft cloth.
2. Use cotton swabs to clean hard to reach areas. Pay special attention to the frame rails, takedown lever and slide catch lever.
3. Lubricate the frame rails with a light coat of CLP.
4. Apply CLP to accessible functioning parts.
5. Clean the magazine well of any dirt, dust or residue with a soft cloth.

### MAGAZINE

1. Wipe the magazine tube and follower with a cloth. Clean the magazine tube and follower with a soft brush and CLP.
2. Use a cloth to clean the magazine spring, floor plate, and base plate.
3. Apply a light coat of CLP to the spring and magazine tube.

## 7.4 PISTOL ASSEMBLY

1. Verify that the each part is clear of all foreign matter.
2. Insert barrel into slide.

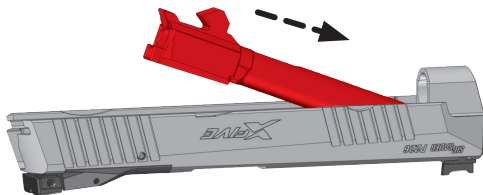

## CAUTION



**WARNING PARTS UNDER SPRING TENSION**



**THE RECOIL SPRING AND GUIDE ARE UNDER SPRING TENSION AND NOT FIRMLY ATTACHED TO THE SLIDE. USE CAUTION TO PREVENT INJURY OR DAMAGE TO THE PISTOL. WEAR EYE PROTECTION.**

**FAILURE TO PROPERLY INSTALL THE RECOIL SPRING GUIDE, BUFFER, AND BUFFER SPRING CAN CAUSE DAMAGE TO THE PISTOL.**



## 7.4 PISTOL ASSEMBLY - CONTINUED

3. Ensure the buffer cup is in the correct orientation, insert the recoil spring into the open end of the buffer cup.

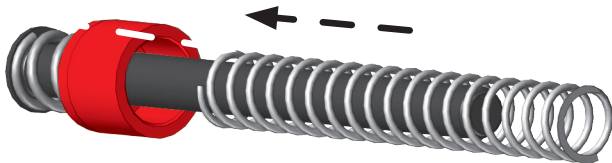

4. Insert recoil spring and guide into slide.

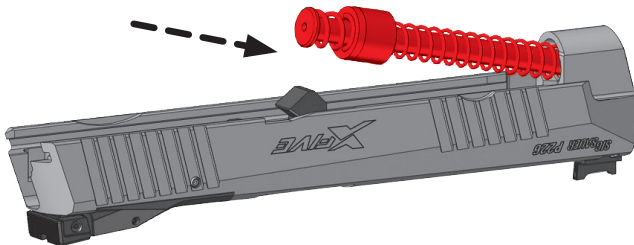

5. Ensure takedown lever is rotated clockwise to the vertical position (6 o'clock).

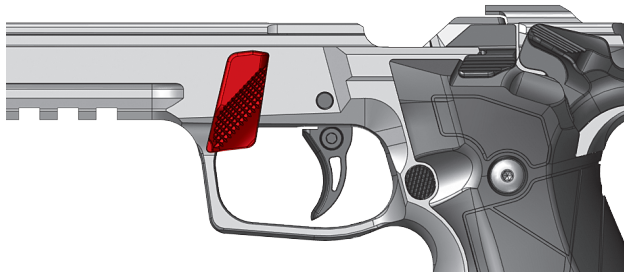

FAILURE TO DEPRESS THE SAFETY LEVER WHILE INSTALLING THE SLIDE CAN CAUSE DAMAGE TO THE PISTOL.

6. Make sure the safety lever is down. Push it down with light finger pressure. When in the “down” position the firing pin safety lever will sit flush or slightly above the frame rail.



## 7.4 PISTOL ASSEMBLY - CONTINUED

SAFETY  
LEVER

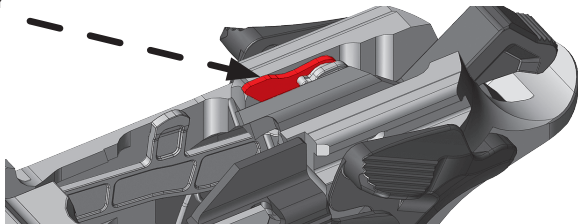

7. Guide slide onto frame rails from the front. The slide should go on the frame and over the firing pin safety lever with no resistance other than compression of the recoil springs.
8. Retract slide fully to the rear and push up on slide catch lever to lock slide in the open position.

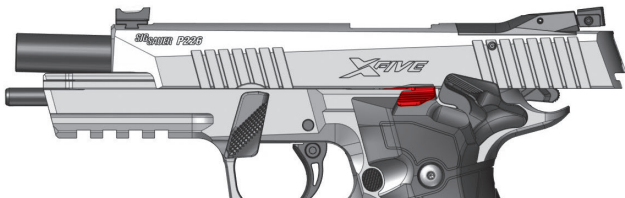

9. Rotate takedown lever counterclockwise until horizontal.



10. Press slide catch lever to release slide.





## 7.4 PISTOL ASSEMBLY - CONTINUED

11. Engage the manual safety.
12. If your pistol has a sport takedown lever, push up slightly on the takedown lever and push on the right side of the trigger pin, exposing it on the left side of the frame. Rest the take down lever in the notch of the trigger pin.

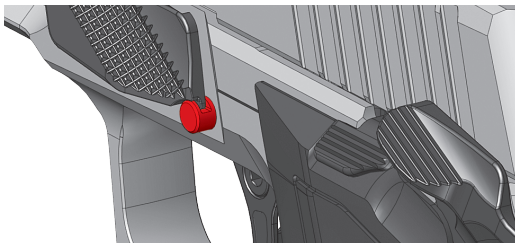
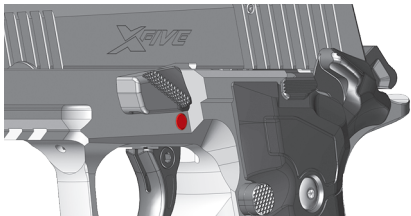



## 7.5 MAGAZINE ASSEMBLY

1. Position magazine follower on magazine spring and insert into the bottom of magazine tube.



**WARNING PARTS UNDER SPRING TENSION**



**THE MAGAZINE SPRING IS BEING COMPRESSED DURING ASSEMBLY. GUARD THE MAGAZINE INSERT AND MAGAZINE SPRING. UNCONTROLLED RELEASE CAN CAUSE INJURY. WEAR EYE PROTECTION.**

2. Insert magazine spring fully into magazine tube until magazine insert is flush with magazine tube bottom.

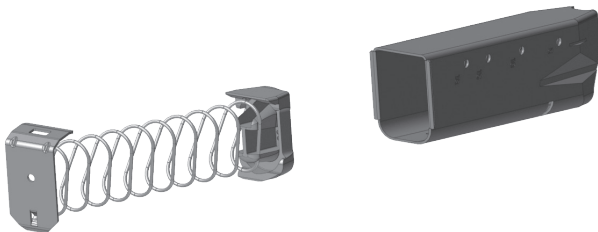



## 7.5 MAGAZINE ASSEMBLY - CONTINUED

3. Holding magazine insert in place, slide magazine floor plate onto magazine tube lips until magazine floor plate is locked in place by magazine insert.

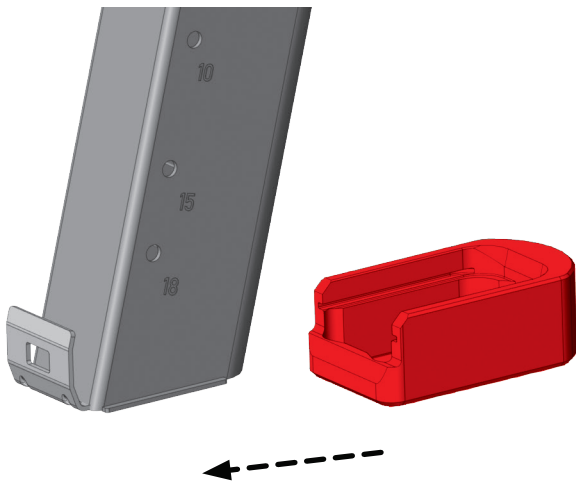

## 7.6 FUNCTION CHECK

The function check is performed on the assembled pistol to verify functionality. It should be performed after the completion of each cleaning and assembly of the pistol.



**WARNING**

**UNLOAD/CLEAR**



**VERIFY THE MAGAZINE IS REMOVED. VISUALLY AND PHYSICALLY CONFIRM THE PISTOL IS UNLOADED AND CLEARED, REMOVE ALL AMMUNITION FROM THE AREA BEFORE THE BEGINNING OF THE FUNCTION CHECK. FAILURE TO ENSURE THE FIREARM IS UNLOADED AND CLEARED COULD RESULT IN UNINTENTIONAL DISCHARGE, CAUSING SEVERE INJURY OR DEATH, OR PROPERTY DAMAGE. VERIFY THE FIREARM IS UNLOADED AND CLEARED.**

1. Ensure the pistol is unloaded and cleared. Keep live ammunition out of the work area.
2. Insert an empty magazine into the magazine well and ensure the magazine catch locks magazine into the frame.
3. Retract the slide completely rearward and ensure the slide catch lever locks the slide to the rear.
4. Press the magazine catch. The empty magazine should fall free of the frame under its own weight.



## 7.6 FUNCTION CHECK - CONTINUED

5. Pull the slide back slightly and watch that the slide catch lever drops allowing the slide to move forward.
6. Release the slide and let the recoil spring assembly drive the slide forward into battery.
7. Push up the manual safety lever to engage the safety. The hammer will be in the cocked position at this time.
8. With the pistol pointed in a safe direction, press the trigger. The hammer must not fall.
9. Press the manual safety lever down to disengage.
10. Press the trigger and hold it to the rear. The hammer should now drop, striking the firing pin.
11. Retract the slide completely to the rear and release. The hammer should now be cocked to the rear.
12. Release the trigger.
13. Press the trigger. The hammer should drop.

### CAUTION

NEVER USE A FIREARM OR MAGAZINE THAT SHOWS SIGNS OF DAMAGE OR FAILS A FUNCTION CHECK. VERIFY THE MAGAZINE IS THE CORRECT MODEL AND CALIBER FOR THE PISTOL. IF THE CONDITION OR FUNCTION OF THE PISTOL OR MAGAZINE IS SUSPECT, RETURN THE PISTOL OR MAGAZINE TO SIG SAUER FOR EVALUATION. VERIFY THE CONDITION AND FUNCTION.

## 8.0 MAGAZINE CATCH REMOVAL AND REVERSAL

P226 XFIVE is designed for both right hand and left hand operation. The magazine catch may be repositioned to either side based on shooter preference.



**WARNING**

**UNLOAD/CLEAR**



**VERIFY THE MAGAZINE IS REMOVED, VISUALLY AND PHYSICALLY CONFIRM THE PISTOL IS UNLOADED AND CLEARED, REMOVE AMMUNITION FROM THE AREA BEFORE ATTEMPTING DISASSEMBLY OR PERFORMING ANY MAINTENANCE STEPS. FAILURE TO ENSURE THE FIREARM IS UNLOADED AND CLEARED COULD RESULT IN UNINTENTIONAL DISCHARGE, CAUSING SEVERE INJURY OR DEATH, OR PROPERTY DAMAGE. VERIFY THE FIREARM IS UNLOADED AND CLEARED.**



## 8.1 MAGAZINE CATCH REMOVAL

Before removing and reversing the magazine catch ensure the pistol is completely unloaded and cleared. Removing the slide as described in “7.1 Pistol Disassembly” on page 59, as well as the grips will provide better access to the magazine catch.

1. Using a T10 drive bit remove grip screws and grips from the frame, being careful not to lose the rubber magwell shims. See page 91 for magwell shim information.
2. Press magazine catch until the back protrudes slightly from the opposite side and hold.
3. On the protruding side, press the straightened end of a paper clip into the hole on the back side of magazine catch to release magazine catch stop.

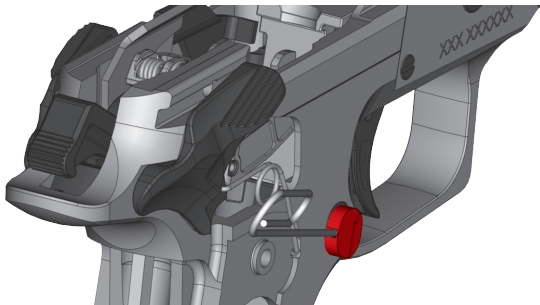

4. Remove magazine catch stop.
5. Remove magazine catch and magazine catch spring, keeping the two pieces together.





## 8.2 MAGAZINE CATCH INSTALLATION

6. Insert magazine catch and magazine catch spring on the desired side of the pistol body.
7. Press magazine catch into the frame until it protrudes out the opposite side and hold it in position.





8. Insert magazine catch stop from the opposite side until magazine catch stop latch engages and release magazine catch.

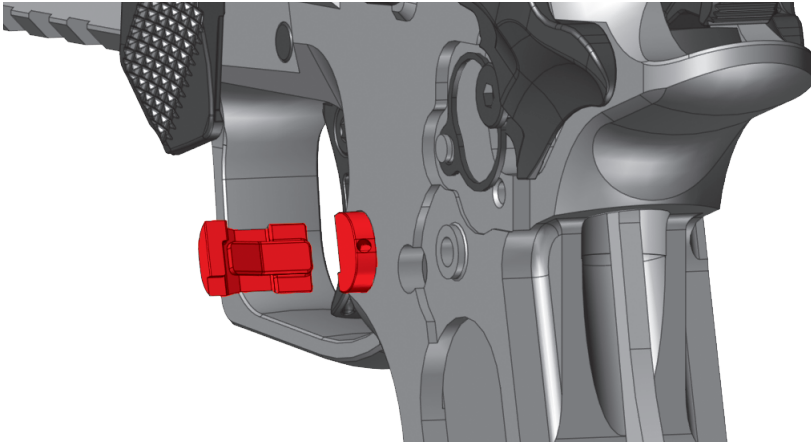

9. Reinstall magwell shims, see page 91 for alignment, align grip panels on frame, install grip screws to 13 in-lb.



## 8.3 MAGAZINE FUNNEL REMOVAL AND INSTALLATION

The SIG SAUER P226 XFIVE pistols come with a detachable magazine funnel. This magazine funnel facilitates faster reloading of the pistol. You can detach the funnel from the frame by removing the grip panels and sliding the funnel to the rear.

### 8.3.1 MAGAZINE FUNNEL REMOVAL

1. Using a T10 drive bit remove grip screws and grips from the frame.
2. Use firm even pressure to slide the magazine funnel and magwell shims from the rear of the frame.



### 8.3.2 MAGAZINE FUNNEL INSTALLATION

1. Insert tabs on magazine funnel on rails of the frame and using steady even pressure slide funnel onto frame until it stops, add magwell shims to top of magazine funnel.
2. Place and align grip panels on frame, install grip screws to 13 in-lb.

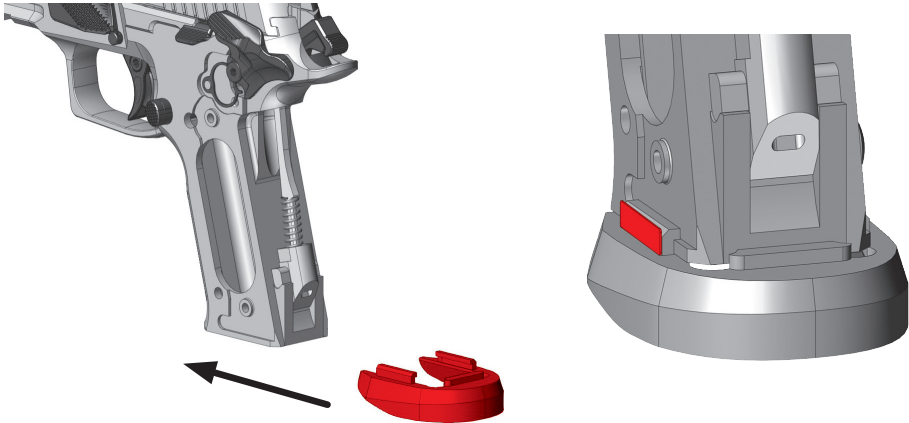



## 9.0 SIGHTS



**WARNING**

**TRITIUM SIGHTS**



**SOME SIG SAUER PISTOLS COME EQUIPPED WITH SIGHTS THAT CONTAIN RADIOACTIVE MATERIAL FOR ILLUMINATION DURING LOW LIGHT CONDITIONS OR HOURS OF DARKNESS. THE SIGHTS ARE MARKED WITH THE LETTERS “SIG” AND “H3.” THE RADIATION SOURCE IS HYDROGEN-3 (H3), COMMONLY KNOWN AS TRITIUM. THE ACTIVITY LEVEL OF TRITIUM IN SIG SAUER NIGHT SIGHTS RANGE FROM 12 MCI (MILLICURIES) TO 30 MCI. THE OPERATIONAL TEMPERATURE RANGE OF SIG SAUER TRITIUM SIGHTS IS  $-30^{\circ}\text{C}/-22^{\circ}\text{F}$  TO  $+60^{\circ}\text{C}/+140^{\circ}\text{F}$ . THE BETA RADIATION EMITTED BY TRITIUM IS ONLY A HAZARD IF THE TRITIUM VIAL IS BROKEN AND IS INGESTED OR INHALED BY HUMANS. THE BODY DOES NOT EASILY RETAIN HYDROGEN OR TRITIUM AS A GAS. HOWEVER, THE OXIDE HTO, WHICH IS FORMED BY THE BURNING OF TRITIUM IS 10,000 TIMES MORE HAZARDOUS. FOR THIS REASON GREAT CARE SHOULD BE TAKEN TO AVOID FLAME IN THE PRESENCE OF DAMAGED TRITIUM SIGHTS. DISPOSAL OF TRITIUM SIGHTS MUST BE PERFORMED IN A CONTROLLED MANNER. IF YOU SUSPECT THAT THE SIGHT CONTAINING A TRITIUM VIAL HAS BROKEN, DO NOT ATTEMPT TO DISASSEMBLE THE SIGHT. FOLLOW THESE INSTRUCTIONS.**

**DAMAGED SIGHTS ONLY (SIGHTS REMOVED FROM FIREARM):**

**PLACE DAMAGED SIGHTS IN A SMALL ZIP LOCK BAG AND LABEL IT “DAMAGED TRITIUM SIGHT DO NOT OPEN,” PLACE THE ZIP LOCK BAG IN A SHIPPING ENVELOPE MARKED “NIGHT SIGHT FOR DISPOSAL” AND SEND TO:**

**SIG SAUER, INC.  
357 SIG SAUER DRIVE  
JACKSONVILLE, AR 72076**

**SLIDE WITH DAMAGED SIGHTS:**

**CALL CUSTOMER SERVICE AT (603) 610-3000 EXT.1 FOR INSTRUCTIONS AND RETURN AUTHORIZATION.**

**WARNING****TRITIUM SIGHTS** — —

**DO NOT DISCARD TRITIUM SIGHTS IN THE TRASH**

**AFTER CONTACT WITH A SUSPECTED DAMAGED TRITIUM SIGHT, WASH YOUR HANDS CAREFULLY WITH SOAP AND WATER. DO NOT HANDLE DAMAGED SIGHTS IF YOU HAVE OPEN SKIN CUTS OR ABRASIONS. DO NOT EAT, DRINK, SMOKE OR APPLY COSMETICS IN THE PRESENCE OF A DEFECTIVE SIGHT VIAL.**



## 9.1 GENERAL INFORMATION

The SIG SAUER P226 XFIVE pistols are equipped with a fixed front fiber optic sight and a fully adjustable rear sight assembly that have proven their worth under severe conditions. The sights consist of a fully adjustable rear sight and a front sight blade, designed and dimensioned to ensure rapid target acquisition even when visibility is poor.

### CAUTION

SIG SAUER SUGGESTS THAT FIXED-SIGHT CORRECTIONS SHOULD BE PERFORMED ONLY BY A CERTIFIED SIG SAUER ARMORER OR CERTIFIED GUNSMITH. OTHERWISE THE PISTOL COULD BECOME DAMAGED.

## 9.2 SIGHT ADJUSTMENT



**WARNING**

**SIGHT ADJUSTMENT**



**SIGHT CORRECTIONS SHOULD ONLY BE PERFORMED ON AN UNLOADED FIREARM. MANIPULATING THE SIGHTS ON A LOADED FIREARM COULD RESULT IN UNINTENTIONAL DISCHARGE, CAUSING SEVERE INJURY OR DEATH, OR PROPERTY DAMAGE. VISUALLY AND PHYSICALLY CONFIRM THE PISTOL IS UNLOADED AND CLEARED BEFORE MAKING SIGHT ADJUSTMENTS. DO NOT ADJUST SIGHTS ON A LOADED FIREARM.**

## NOTE

SIG SAUER has a Sight Adjustment Tool available that makes it easier to adjust and change fixed sights.

The SIG SAUER P226XFIVE is equipped with an adjustable rear sight assembly with audible and tactile clicks to help keep track of sight adjustments.

### **9.2.1 ELEVATION ADJUSTMENT**

Elevation: Counterclockwise rotation of the screw will raise the rear sight, moving the point of impact up. Clockwise rotation of the screw will lower the rear sight, moving the point of impact down.

### **9.2.2 WINDAGE ADJUSTMENT**

Windage: Counterclockwise rotation of the windage screw will move the rear sight aperture left, moving the point of impact left. Clockwise rotation of the screw will move the rear sight aperture right, moving the point of impact right.



## 9.2 SIGHT ADJUSTMENT - CONTINUED

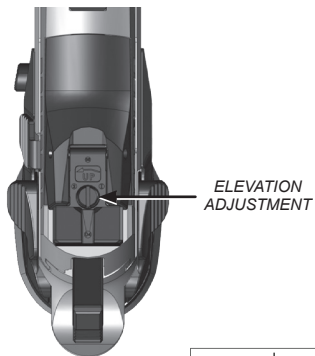

WINDAGE  
ADJUSTMENT

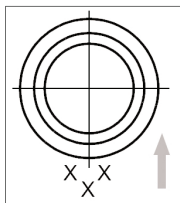

Impact low of point of aim

Impact left of point of aim

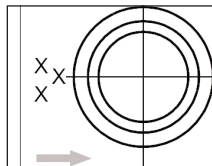



## 10.0 TRIGGER ADJUSTMENT

The SIG SAUER P226XFIVE is equipped with a 3 way adjustable AX3 trigger with adjustments for reach, weight and overtravel. Each adjustment comes factory preset but may be altered if desired.

### 10.1 REACH ADJUSTMENT

1. Ensure the pistol is unloaded and cleared. Keep live ammunition out of the work area.
2. Loosen screw on side of trigger shoe using a 2.5mm driver.
3. Slide trigger shoe to desired position.
4. Re-tighten screw to 15 in lb.

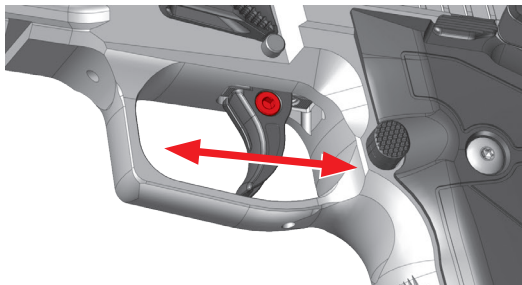



## 10.2 TRIGGER PULL WEIGHT ADJUSTMENT

The weight of the trigger pull is adjustable from approximately 2.5 to 4 pounds

1. Ensure the pistol is unloaded and cleared. Keep live ammunition out of the work area.
2. Locate adjustment screw at intersection of trigger guard and rail
3. Using a 2mm or 5/64" hex driver. turn counterclockwise to reduce pull weight, clockwise to increase. \*If the screw stops turning DO NOT force it; you have reached the limit in that direction.

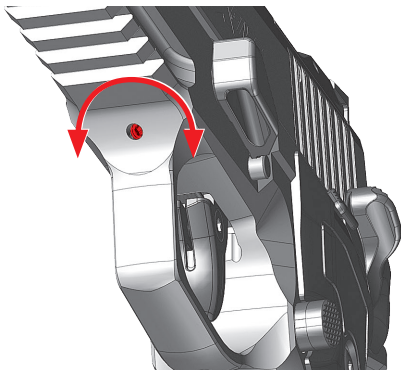

### 10.3 TRIGGER OVERTRAVEL ADJUSTMENT

## NOTE

Turning the adjustment screw too far clockwise will prevent the pistol from firing.

1. Ensure the pistol is unloaded and cleared. Keep live ammunition out of the work area.
2. Locate adjustment screw behind trigger shoe, using a 2mm or 5/64" hex driver, turn counterclockwise to increase overtravel, or clockwise to decrease.

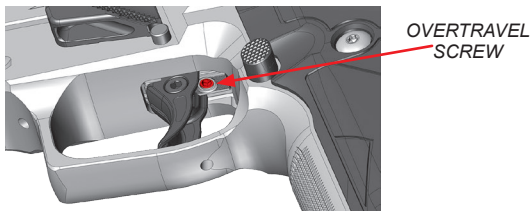

3. If pressing the trigger does not release the hammer, turn the screw counterclockwise in very small increments until the hammer is able to be released.
4. Once the hammer is able to be released, turn the screw an additional 1/8 turn counterclockwise to ensure reliability. This is the minimum recommended overtravel for reliable operation.



## 10.4 TRIGGER SHOE REMOVAL AND INSTALLATION

### 10.4.1 TRIGGER SHOE REMOVAL

1. Ensure the pistol is unloaded and cleared. Keep live ammunition out of the work area.
2. Remove screw on side of trigger shoe using a 2.5mm driver.
3. Pushing away from the center of the trigger base, apply pressure to the side of the trigger shoe, The trigger shoe will rotate and one side of the trigger shoe will be freed from the trigger base rail, allowing the trigger shoe to be removed by pushing the remaining leg of the trigger up and off of the trigger base rail

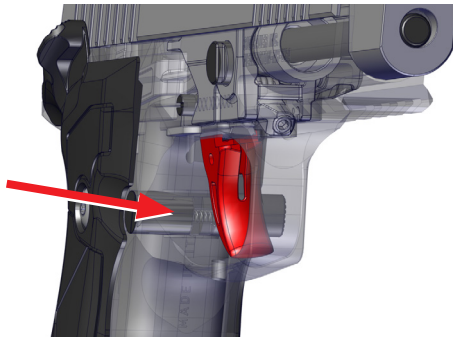
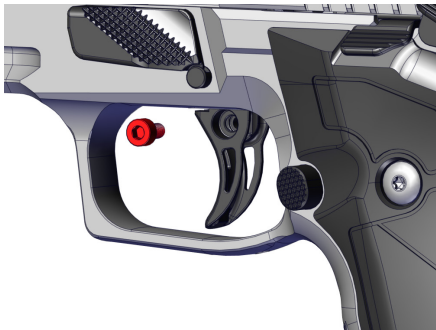

## 10.4.2 TRIGGER SHOE INSTALLATION

1. Ensure the pistol is unloaded and cleared. Keep live ammunition out of the work area.
2. Hook the upper leg of the trigger shoe on the top of the trigger base rail, press trigger shoe towards the center of the trigger base until the trigger shoe rotates onto the trigger base rail and seats firmly with an audible click.
3. Using a 2.5mm driver, insert screw into trigger shoe and tighten to 15 in lb.

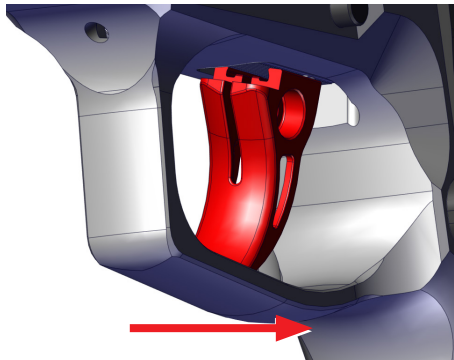



## 10.5 SIGHT PLATE REMOVAL AND INSTALLATION

### 10.5.1 SIGHT PLATE REMOVAL

1. Disassemble pistol. See section, “7.1 Pistol Disassembly” on page 59.
2. Use T10 drive bit to remove the sight plate screws from bottom of slide.

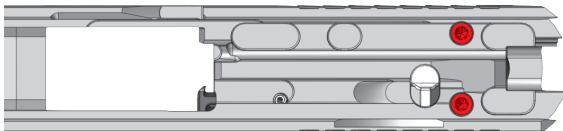

3. Lift sight and plate from slide.

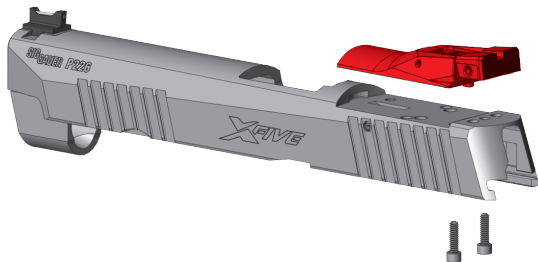

## 10.5.2 SIGHT PLATE INSTALLATION

### NOTE

Sight plate screws are for securing the rear sight and sight plate only.

1. Insert sight plate screws into the bottom of slide and tighten to 15 in-lb using a T10 drive bit.

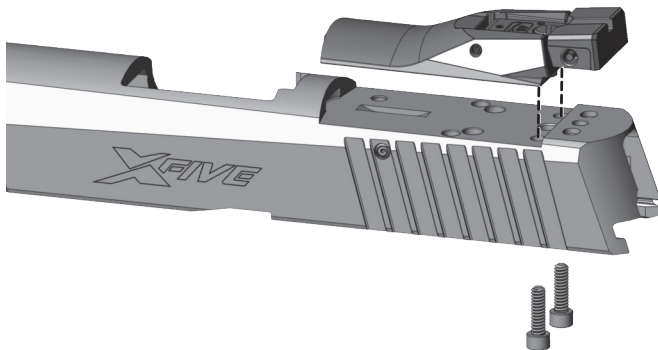



## 10.6 ROMEO INSTALLATION

1. Insert ROMEO into shroud (if equipped).

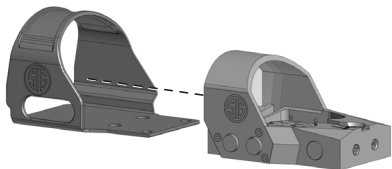

2. Place ROMEO and shroud assembly on slide aligning holes.

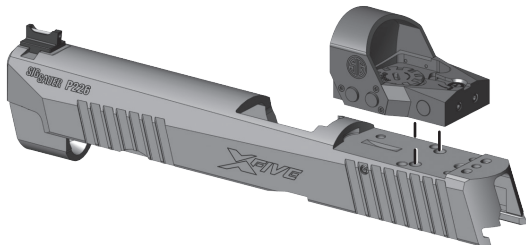



3. Install ROMEO screws with T15 drive bit and torque to 25 in-lb.



4. Refer to ROMEO manual for zeroing and sight adjustments.



## 11.0 STORAGE AND TRANSPORTATION

### 11.1 STORAGE



**WARNING**

**UNLOAD/CLEAR**



**YOU MUST UNLOAD AND CLEAR THE FIREARM PRIOR TO STORING THE PISTOL (SEE SECTION 5.0).**

Never place or store any firearm in such a manner that it may be dislodged. Firearms should always be stored securely and unloaded, away from children and other unauthorized users. Use the locking device originally supplied with this firearm for storage. The use of a locking device or safety lock is only one aspect of responsible firearms storage. For increased safety, firearms should be stored unloaded and locked in a location that is both separate from their ammunition and inaccessible to children and any other unauthorized person.

**SHORT-TERM STORAGE (90 DAYS OR LESS)**

1. Ensure that chamber and magazine do not contain live ammunition.
2. Clean bore and chamber.
3. Apply a light coat of CLP to the chamber and bore.
4. Apply a light coat of CLP to all other metal surfaces for corrosion protection.

**LONG-TERM STORAGE (90 DAYS OR LONGER)**

1. Ensure that pistol is thoroughly cleaned.
2. Apply a heavy coat of CLP to chamber and bore.
3. Apply a heavy coat of CLP to all other metal surfaces for corrosion protection.
4. Wrap the firearm with a waterproof material (MIL-B-121 or similar).
5. Place the firearm in a corrosion resistant barrier bag (MIL-DTL-117 or similar).

**ENVIRONMENTAL STORAGE**

Provide humidity control to limit the relative humidity to no greater than 40% RH at 80 degrees Fahrenheit (26.7 degrees Celsius). If personnel will be working in these areas, design to 68 degrees F (20.0 degrees C) dry bulb and 40% RH for indoor design heating conditions, and 75 degrees F (23.9 deg C) dry bulb and 40% RH for indoor design cooling conditions.



## 11.2 TRANSPORTATION



**WARNING**

**UNLOAD/CLEAR**



**YOU MUST UNLOAD AND CLEAR THE FIREARM PRIOR TO TRANSPORTING THE PISTOL  
SEE, “5.0 UNLOADING THE PISTOL” ON PAGE 50.**

IT IS YOUR RESPONSIBILITY TO FAMILIARIZE YOURSELF WITH THE LAWS OF ANY STATE  
YOU ARE PLANNING TO TRAVEL THROUGH WITH YOUR FIREARM.

When transporting your firearm to and from shooting activities, keep it unloaded for your safety and for the safety of others. When storing your firearm for transportation, keep it separated from ammunition, under lock and key if possible, and out of the reach of children and other inexperienced or unauthorized persons.

If transporting the firearm in a vehicle, ensure that it is secured within the confines of the vehicle. Should the vehicle become involved in an accident, you do not want the firearm to become dislodged and move about the interior of the vehicle or be ejected from the vehicle.

## 12.0 PARTS POLICY

**WARNING****PARTS REPLACEMENT**

**IMPROPER FITTING OF PARTS MAY RESULT IN A DANGEROUS MALFUNCTION, DAMAGE TO THE FIREARM, AND SERIOUS INJURY TO THE SHOOTER AND OTHER PERSONS.**

Our Service Department maintains a full complement of replacement parts. Even though most gunsmiths have the knowledge, training, and the ability to make necessary repairs to your firearm, the skill and workmanship of any particular gunsmith is totally beyond our control.

Should your firearm ever require service, we strongly recommend that you return it to SIG SAUER. A firearm is a precision instrument and some replacement parts will require individual fitting to ensure correct operation. A wrong part, improper fitting, or incorrect mechanical adjustment may result in an unsafe condition or dangerous malfunction, damage to the firearm, or cause possible serious injury to the shooter or others.

IF ANY PART IS ORDERED WITHOUT RETURNING THE FIREARM TO SIG SAUER INC., the customer bears full responsibility for ensuring that the part supplied is correct for their particular firearm and is properly installed and fitted by a qualified gunsmith.

It is the purchaser's responsibility to be absolutely certain that any parts ordered from the factory are correctly fitted and installed. Firearms are complicated mechanisms and the purchaser and installer of parts must accept full responsibility for the correct adjustment and functioning of the firearm after such installation. SIG SAUER IS NOT RESPONSIBLE FOR THE FUNCTIONING OF ANY FIREARM IN WHICH REPLACEMENT PARTS ARE INSTALLED BY OTHERS.



## 13.0 SERVICE POLICY

If you have questions concerning the performance or servicing of your firearm, please write or call:

SIG SAUER, Inc.  
Attention: Customer Service  
18 Industrial Drive, Exeter, NH 03833  
Phone: (603) 610-3000 ext. 1  
Fax: (603) 766-7002

IF YOU DO NOT UNDERSTAND THE INSTRUCTIONS FOR OPERATING YOUR PISTOL, IT IS YOUR RESPONSIBILITY TO CALL OUR CUSTOMER SERVICE DEPARTMENT AT (603) 610-3000 EXT. 1 BEFORE USING YOUR FIREARM.

## 14.0 SHIPPING FIREARMS FOR REPAIR



**WARNING**

**DO NOT SHIP AMMUNITION**



In the event you need to return your firearm to the SIG SAUER Service Department, here's what to do:

1. First contact Customer Service at (603) 610-3000 ext. 1 for an RMA number, which will allow SIG SAUER to track the status of your return from its receipt at SIG SAUER through its return to you. Please do not send your firearm until you obtain an RMA number.
2. Make sure that the chamber and magazine(s) are unloaded and that no ammunition is included with your returned firearm.
3. Package the firearm securely to prevent damage. Enclose a letter that includes your name, street address, daytime phone number, model and serial number, and a detailed description of the problem you have experienced or the work you want performed. With the exception of extra magazines, do not include any other accessories such as scopes or mounts.
4. Generally, an individual may ship firearms to the manufacturer for repair or service. Some states and localities, however, prohibit this. If you live in such an area, the firearms must be shipped by and returned to a federally licensed firearms dealer.



## 14.0 SHIPPING FIREARMS FOR REPAIR - CONTINUED

5. Federal law prohibits persons who do not possess a Federal Firearms License from shipping a firearm via the U.S. Postal Service. (Note: any shipment of firearms outside U.S. borders is subject to the export laws of the United States and to the valid laws of the specific country, which you must strictly follow; prior to exporting any firearm you should seek legal counsel.)
6. SIG SAUER is not responsible for any firearm until it is received, nor for damage incurred during shipment.
7. Ship your firearms insured and prepaid (we do not accept collect shipments) to:

SIG SAUER, Inc.  
Attention: Service Department  
18 Industrial Drive Exeter, NH 03833

Don't forget to write your RMA number on the package.

A copy of this instruction manual should always accompany this pistol and be transferred with it upon change of ownership.



## 15.0 STANDARD SLIDE PARTS DIAGRAM

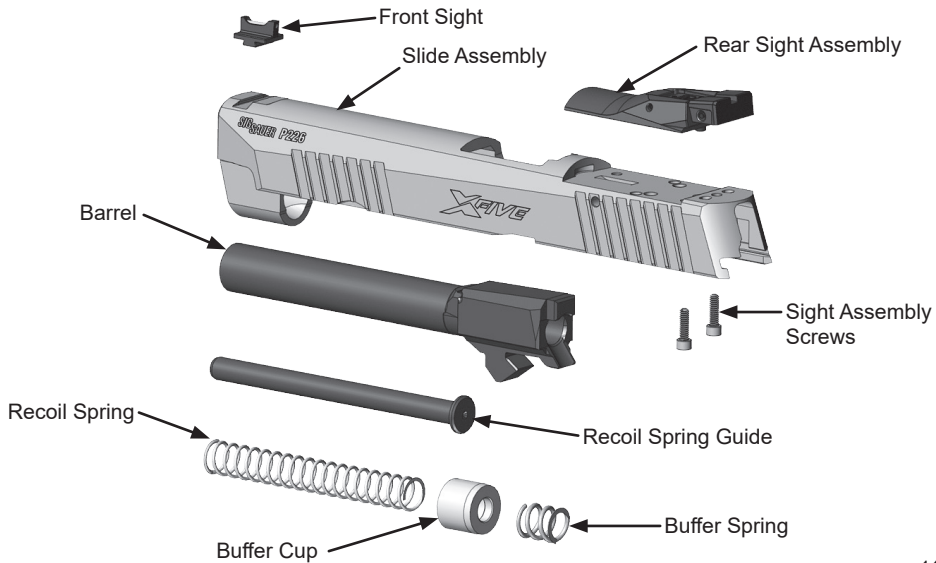



## 15.1 FRAME DIAGRAM

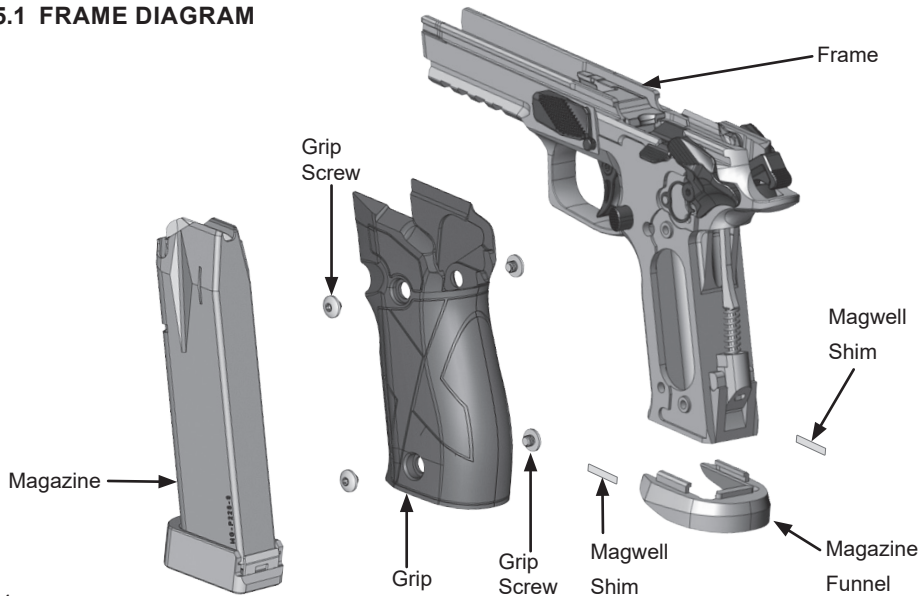

## 16.0 TECHNICAL SPECIFICATIONS

The Following Information applies to the SIG SAUER P226 XFIVE pistol.

- Traditional hammer fired system.
- Left hand or right hand operation (magazine catch repositions to either side, ambidextrous manual safety).
- All metal frame with integral accessory rail.
- Adjustable Single Action trigger.
- Solid high-strength stainless steel slide with front and rear cocking serrations.

Scan this QR code for info right on your smart phone. Use your favorite QR app to download your Operator's Manual, see special offers, instructional videos, and more from SIG SAUER.





## **SIG SAUER® Firearms Limited Lifetime Warranty**

SIG SAUER warrants that the enclosed firearm was originally manufactured free of defects in material, workmanship, and mechanical function. For the lifetime of the original purchaser, SIG SAUER agrees to correct any defect in the firearm for the original purchaser by repair, adjustment, or replacement, at SIG SAUER's option, with the same or comparable quality components (or by replacing the firearm at SIG SAUER's option); provided however that a Return Merchandise Authorization (RMA) is first obtained by contacting SIG SAUER Customer Service, and the firearm is returned unloaded and freight prepaid to:

SIG SAUER  
18 Industrial Drive,  
Exeter, NH 03833.

This limited warranty is null and void if the firearm has been misused, damaged (by accident or otherwise), fired with handloaded, reloaded, or improper ammunition, fired with an obstruction in the barrel, damaged through failure to provide reasonable and necessary maintenance as described in the manual accompanying the firearm, or if unauthorized repair or any alteration, including of a cosmetic nature, has been performed on the firearm. This limited warranty does not apply to normal wear and tear of any parts.

Subject to the foregoing, this limited warranty confers the right to have the covered firearm or its parts repaired, adjusted, or replaced exclusively upon the original purchaser, which right is not transferable to any other person. This warranty does not apply to any accessory items attached or appurtenant to the firearm.

ANY WARRANTIES IMPLIED BY LAW, INCLUDING ANY IMPLIED WARRANTIES OF MERCHANTABILITY OR FITNESS FOR A PARTICULAR PURPOSE, ARE EXPRESSLY DISCLAIMED. REPAIR, ALTERATION, OR REPLACEMENT AS PROVIDED HEREIN IS YOUR EXCLUSIVE REMEDY FOR ANY DEFECTIVE PRODUCT. IN NO EVENT SHALL SIG SAUER OR ANY COMPANY AFFILIATED WITH SIG SAUER BE LIABLE FOR ANY SPECIAL, INCIDENTAL, OR CONSEQUENTIAL DAMAGES OF ANY KIND ARISING OUT OF THE PURCHASE OR USE OF THIS PRODUCT, WHETHER BASED UPON CONTRACT, TORT, STATUTE, OR OTHERWISE.

Some states do not allow the exclusion or limitation of implied warranties, or the exclusion or limitation of incidental or consequential damages, so some or all of the above limitations or exclusions may not apply to you. This warranty gives you specific legal rights, and you may also have other rights which vary from State to State.

THIS WARRANTY APPLIES TO U.S. COMMERCIAL CUSTOMERS ONLY, AND DOES NOT APPLY TO GOVERNMENT, MILITARY, LAW ENFORCEMENT, OR NON-US CUSTOMERS. NON-US CUSTOMERS SHOULD CONTACT THEIR LOCAL DEALER OR DISTRIBUTOR FOR APPLICABLE WARRANTY COVERAGE.

# **SIG SAUER®**

[sigsauer.com](https://www.sigsauer.com)

**SIG SAUER, Inc.**  
**72 Pease Boulevard, Newington, NH 03801 USA**

All trademarks, service marks, trade names, trade dress, product names and logos appearing in this manual are the property of their respective owners. No trademark or service mark appearing in this manual may be used without written consent of the mark's owner.